



ONE AAC

PANEL

AAC FIRE & ACOUSTIC SOLUTIONS

50mm & 75mm AAC FLOOR SYSTEMS

DESIGN & INSTALLATION MANUAL

September 2019 Edition

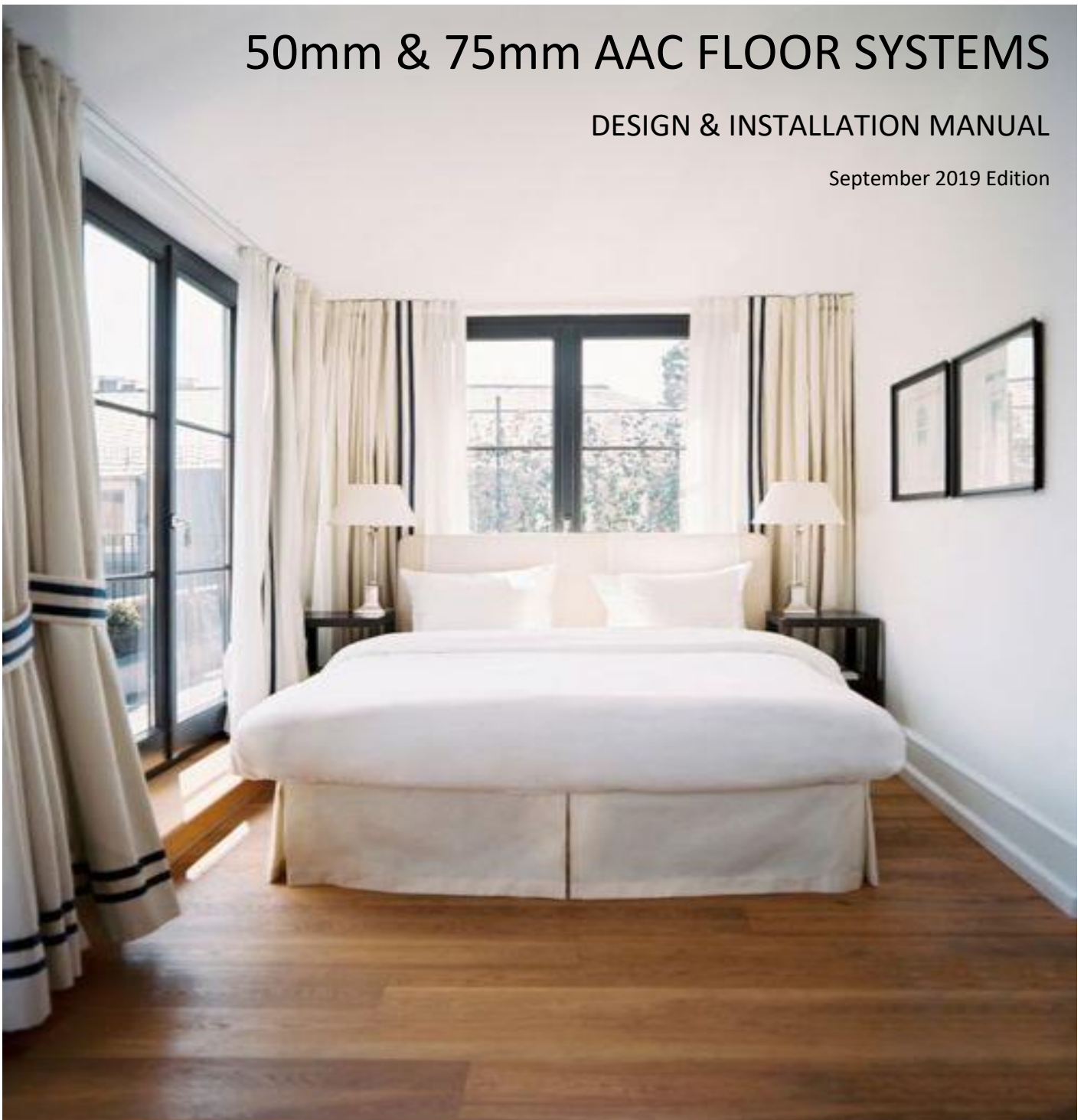

Preface

The ONE AAC PANEL Floor System Design & Installation Manual has been developed to provide design, installation and technical information to 'end users' ranging from the owner builder, licensed builders, building consultants, designers, architects and engineers.

Although the details provided in this Design & Installation Manual have been developed by ONE AAC and are intended to represent good building practice, the registered professionals involved in the project (such as the licensed builder, architectural designer and engineering consultant) must ensure that the information provided in this Design & Installation Manual is appropriate and suitable for the project.

Contents

Introduction To ONE AAC	3-6
❖ What is AAC	
❖ ONE AAC PANEL - Features and Benefits	
❖ Material Properties	
BCA Compliance	7
❖ Compliance with the Building Code of Australia	
System Overview & Performance	8-11
❖ Structure – (Mass, Impact)	
❖ Durability	
❖ Fire Resistance / Bush Fire Zone Compliance	
❖ Energy Efficiency (R-Values)	
❖ Acoustic Performance	
❖ Floor / Ceiling Performance	
System Components	11-12
❖ Panel	
❖ Panel Fasteners	
❖ Adhesive	
❖ Corrosion Protection Paint	
❖ Construction Adhesive	
❖ Flexible and Fire Rated Sealants	
System Installation Process	13-16
❖ System Installation Sequence	
❖ Installation Summary	
❖ Tools & Equipment	
Delivery Storage & Handling	17
❖ Delivery	
❖ Storage and Handling	
Occupational Health and Safety	17
Warranty & Guarantee	18
Drawings & Details	19-25
CodeMark Certificate Of Conformity	26

Introduction

ONE AAC Panel is known as a market leader in Aerated Autoclaved Concrete (AAC) Panel Solutions for residential and commercial construction.

ONE AAC combines 25 years of construction experience, product and systems development knowledge and material distribution expertise, to ensure its customers receive the best construction solutions for their projects, at the best possible price, with the fastest possible turnaround.

ONE AAC provides the construction industry with specialised **Fire** and **Acoustic** Solutions for **wall** and **floor** systems, in both **commercial** and **residential** applications.

Solutions include, but are not limited to:

- Internal Wall Systems (Indoor Walls / Intertency Walls / Party Walls / Corridor Walls. / Shaft Walls) – in both Low Rise and High Rise Residential markets
- External Wall Systems – Rendered Low Rise and High Rise Façades
- Boundary Walls - Single and Torrens Title Dual Wall Options
- **Floor and Ceiling Systems**
- Fence Systems - Boundary and Estate Fencing Solutions

Contact us on **1300 010 222** or www.oneaac.com.au for more information on how these solutions can work for you.

Solutions Can Be Resolved in 50mm or 75mm Thick ONE AAC PANEL - The Choice is Yours.

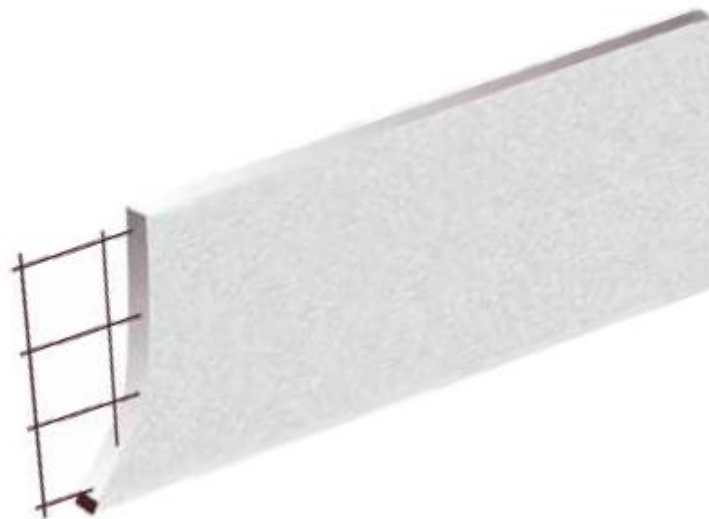

STEEL REINFORCED – 50MM AND 75MM ONE AAC PANEL

What Is AAC? (Lightweight Concrete)

Autoclaved Aerated Concrete (AAC) is manufactured from cement, sand (silica), lime and water, it is aerated by adding an expanding agent to the mix (small amounts of aluminium paste). The mix is poured into a mould (a very large cake tin), to approximately 2/3 of the height of the mould, almost instantly the expanding agent reacts with the other elements, and the mix begins to rise in the mould. (A chemical reaction expands the mixture to form small, finely-dispersed air bubbles).

The moulds are pre-cured in a heated room for several hours. Then the semi-solid material (still in a green state) is transported to the cutting machine. The soft but semi-solid block is sliced into the required panel size using steel wires. Once sliced, the block is steam pressure cured in autoclaves for up to 12 hours. The expanding chemical reaction combined with the Autoclave process is what gives AAC its unique properties. AAC has excellent thermal insulation and acoustic absorption properties, it has superior fire resistance qualities and is also termite resistant.

Its properties and specification satisfy all relevant building codes. Working with AAC is easy and efficient. AAC is both versatile and economical. AAC meets the diverse demands better than any other material due to the numerous advantages of its physical and mechanical properties.

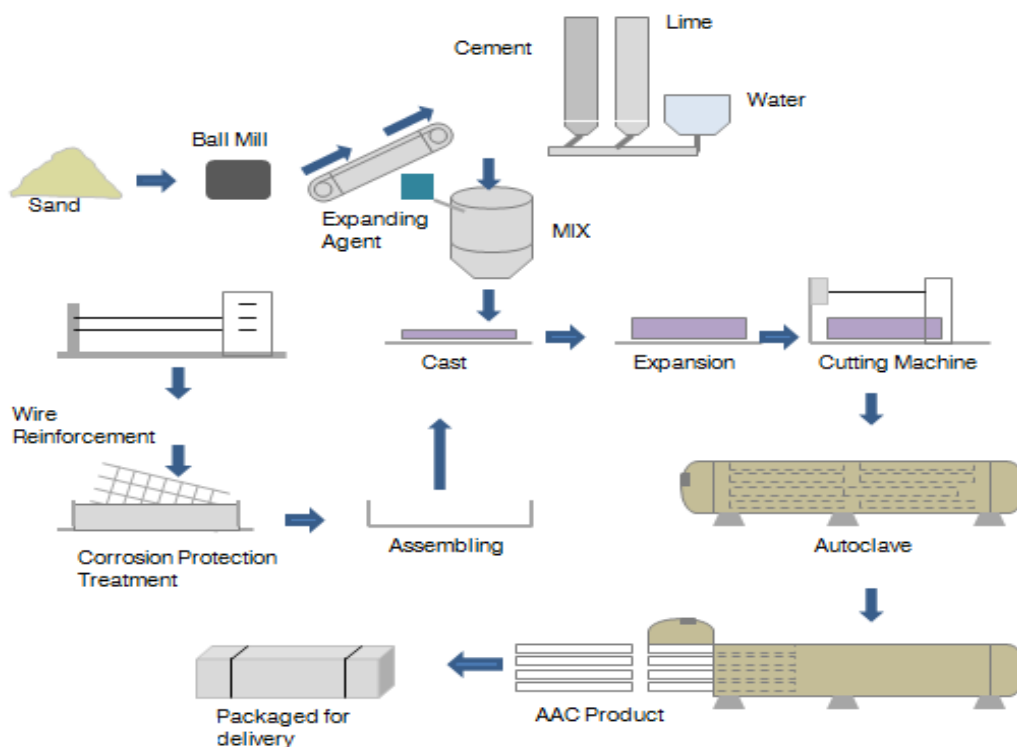

THE ONE AAC PANEL MANUFACTURING PROCESS

ONE AAC PANEL – Why You Should Use It

The ONE AAC Panel Systems provide high-quality Fire and Acoustic Solutions that are lightweight and highly durable, that are perfectly suited to both residential and commercial applications.

The ONE AAC Panel Systems comprise, steel reinforced panels manufactured from autoclaved aerated concrete (AAC). AAC lightweight reinforced panels are a trusted building material; they have been used in the building industry for several decades in Europe and for the last few decades in Australia and New Zealand.

Having one of the largest range of proven construction solutions, ONE AAC PANEL is one of the most trusted AAC Supplier on the market today.



Solid and as durable as masonry yet lightweight

ONE AAC Panels pass the 'knock test' by consumers because they are a masonry product. Further to that, ONE AAC panels are steel reinforced with corrosion protected steel adding to greater strength and security. The average mass of the 50/75mm thick panels are less than 40/62kg respectively, making it a convenient lightweight product, easily installed by a two-man installation process.

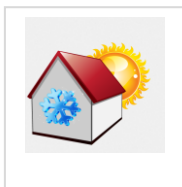

Living in a comfortable environment

The ONE AAC Panel System is able to achieve very good R-Values as a result of the combination of Thermal Mass and Thermal Resistance. The R-Value can be related to the comfort levels within a dwelling. The greater the R-Value, the more comfortable the temperature will be within that dwelling. The ONE AAC Panel System easily achieves the Thermal requirements as set out in the BCA.



High fire resistance adds to the security.

AAC Material is known for its high fire resistance. It will not combust in the event of fire and will not omit toxic gases. The ONE AAC Panel Floor and Ceiling Systems provide a Load Bearing FRL up to 120/120/120. The ONE AAC Panel System also complies with all six (Bush Fire Attack Level Categories (BAL) for external applications.



Sound acoustic qualities

The ONE AAC Panel System provides acoustic performance levels equivalent to other masonry products that are twice as thick. Although the acoustic performance of residential floors (within the same dwelling) is not a requirement of the BCA, it is reassuring to know that acoustic performance is achieved when you use the ONE AAC Panel System.



Design flexibility and aesthetic appeal

ONE AAC provides building designers the flexibility of utilising a masonry product in areas previously restricted to non-masonry products. ONE AAC allows designers and consumers the ability to create that inspirational and contemporary look. With ONE AAC the only limitation to your design is your imagination.



Reduce your Building Cost

The ONE AAC Panel system is simple and flexible insofar as it only requires semi-skilled trades and allows you the choice to self-install using existing lower costs trades or have it supplied and installed by approved installers. Either way this saves you time and money compared to traditional masonry, but still achieving the look and feel of masonry.



Speed of Construction

ONE AAC panels can be delivered flat packed for ease of workability, less labour and with considerable site cost savings. The speed of construction reaches key stages quickly. ONE AAC means a safe and clean worksite with less clean-up at the completion of the project. Two men can easily install an average of 50m² of panel per day.

Material Properties

Property	50MM PANELS		75MM PANELS	
	Value	Units	Value	Units
Ambient ¹ Density, ρ_{amb}	520	kg/m ³	520	kg/m ³
Dry ² Density, ρ_{dry}	500	kg/m ³	500	kg/m ³
Working ³ Density, ρ_{design}	610	kg/m ³	622	kg/m ³
Permanent Action, \bar{G}	0.3	kN/m ²	0.5	kN/m ²
Characteristic Unconfined Compressive Strength, f_{uc}	1.1	MPa	1.1	MPa
Modulus of Rupture, f_{ut}	0.73	MPa	0.73	MPa
Design Ultimate Limit State Bending Capacity, ϕM	0.12	kNm	0.25	kNm
Design Serviceability Limit State Deflection Limit, δ_{max}	SPAN/240		SPAN/240	
Coefficient of contraction	0.4	mm/m	0.4	mm/m
Coefficient of thermal expansion	10	x10 ⁻⁶ /°C	10	x10 ⁻⁶ /°C

Notes:

1. Ambient density is that achieved by the product when it has reached equilibrium at 23°C, 50% RH. The moisture content by mass in this state is typically between 2% and 5%.
2. Dry density is the manufacturer's reported density, the typical frame of reference for grading AAC material. It is achieved by oven drying specimens so that the moisture content is 0%.
3. Working density is to be used for calculation of effects due to permanent actions.
4. Moment capacity quoted is for 600mm wide panels.

Quality from start to finish

It is highly recommended that ONE AAC panels are erected by approved Installers.

With these measures in place plus strict system protocol ONE AAC offers a warranty of 15 years on materials and 7 years on workmanship adding peace of mind to all owners. The manufacturers of ONE AAC PANELS adhere to the ISO 9001 international standards for management of quality.

The ONE AAC Panel System - BCA Compliance

The BCA is part of the Australian National Construction Code system and defines minimum standards for buildings. The BCA consists of two volumes:

Volume One - provides requirements for commercial, residential and public building defined as Class 2 to 9 in the BCA. Typical examples include offices, commercial, health buildings, flats and boarding houses.

Volume Two – Housing Provisions, considers domestic construction defined as Class 1 and 10. Typical examples include houses, garages, swimming pools, carports and the like. The BCA is a performance based building code and contains requirements for Structures, Fire Resistance; Damp & Weatherproofing, Sound Transmissions & Insulation and Energy Efficiency.

The ONE AAC Panel System has been assessed to meet and comply with all the necessary performance requirements of the BCA. This design & Installation Manual contains the information necessary to assist in the design of a project.

The designer should ensure the proposed use of the system satisfies the Performance Requirements and provides sufficient design information (including ONE AAC appraisal and installation manuals) to satisfy the requirements of the appropriate authority.

ONE AAC Panel has achieved the CODEMARK CERTIFICATE OF COMFORMITY issued by Global-Mark in Australia (Certificate Number GM_CM30031 Rev 1) to meet all the required provisions of the Building Code of Australia **for Volume One and Volume Two** and has been appraised as an **Alternative Solution** in terms of compliance with the Building Code of Australia as listed below:



1. **Volume One BP1.1, BP1.2, B1.4 and Volume Two P2.1.1, 3.5.4.0** in respect of structural performance;
2. **Volume One A5.4, C1.1, C1.9 and Volume Two 3.7.2.4, 3.7.3.2/5 and 3.7.4.3** in respect of fire performance;
3. **Volume One FP1.4, F1.9 and Volume Two P2.2.2** in respect of damp weatherproofing;
4. **Volume One F5.2/3/4/5 and Volume Two 3.8.6.2/3/4** in respect of acoustic performance;
6. **Volume One G5.2 and Volume Two 3.10.5.0(c)** in respect of Construction in Bushfire Prone Areas;
7. **Volume One J1.5 and Volume Two 3.12.1.4** in respect of Building Fabric Thermal Insulation;

The Code Mark Certificate is attached in the Appendix of this Design and Installation Manual or visit www.oneaac.com.au to download a copy.

Standard Compliance

All works shall be carried out in accordance with the Building Code of Australia (BCA) and where necessary nominated reference standards.

AS 1720 Timber Framing Code and AS 1684-2006 National Timber Framing Code

AS 2870-1996 Residential Slabs and Footing Construction and AS 3600-2001 Concrete Structures

AS 3959-2009 Construction of Buildings in Bushfire-Prone Zone Areas

AS 2904-1995 Damp-proof course and flashings

AS 1170 Part 1 Loading Code and AS 1170 Part 2 Wind Code

AS 3660.1-2001 Protection of Buildings against subterranean Termite – Part 1 New Buildings

AS 4055-2006 Wind Loading for Housing

AS 3623 and AS/NZ 4600 – Steel Framing and NASH Standard 2005, Part 1 – Steel Framing

Where standards have been revised, the most current version shall apply

For a copy of the relevant compliance documents visit our website: www.oneaac.com.au

ONE AAC Construction Overview

The ONE AAC Panel System is designed to be used in new residential construction, extensions or renovations for houses & Multi-Residential construction using timber or steel frames. The system consists of either 50mm or 75mm thick ONE AAC Panels, reinforced with corrosion protected steel in both directions, installed over a floor joist support system in a “stretcher-bond” pattern.

ONE AAC Panels are available in standard sizes of 2200mm & 1800mm in length for 50mm and 75mm panel respectively and 600mm in width for easy of handling. Longer lengths are available, but the handling and weight of the panels must be considered when selecting longer panels.

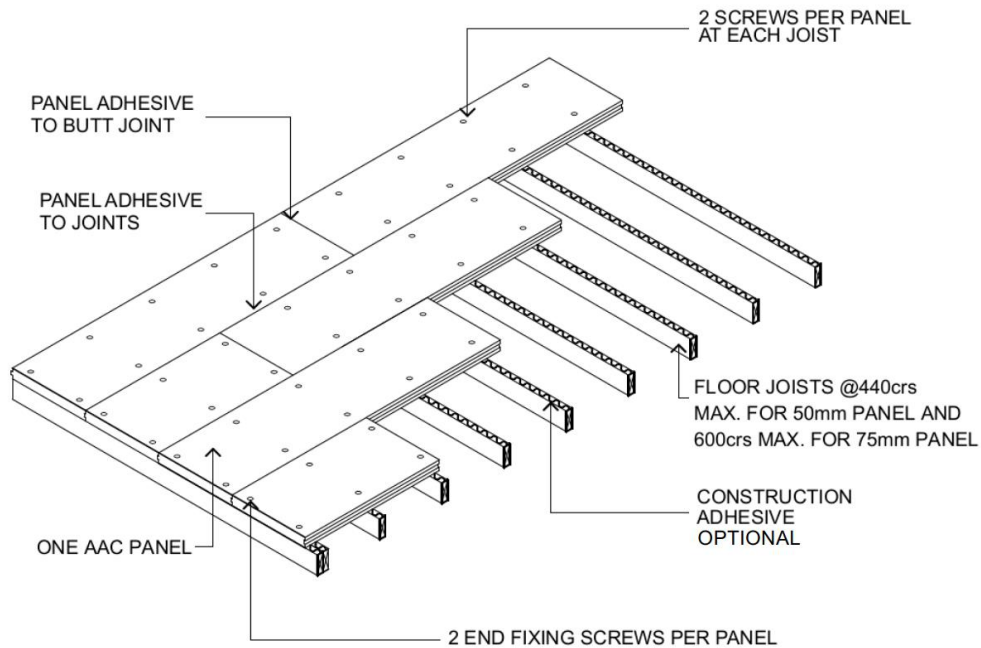

CONSTRUCTION OVERVIEW – Applicable to both 50mm and 75mm ONE AAC Panel

Structure

Loads on the building are transferred from the panels to the support frame (Floor Joist System). The joists are the structural component of the floor system, therefore all structural loads including the mass of the floor panels need to be considered and included when designing the floor system. The floor system should be designed in accordance with the BCA and the relevant Australian Standards.

Mass

The 50mm ONE AAC Panel has an average dry mass of 30.5kg/m² (40kg per 2200mm long panel) and the 75mm ONE AAC Panel has an average dry mass of 55kg/m² (61kg per 1800mm long panel). The designer/engineer’s must allow for the weight of the panel being fixed to the floor joist system in the design and computation process. Within the computations, the type of floor covering should also be considered and allowed for in the calculations.

Impact Resistance

The system has adequate resistance to impact loads that the floor system is likely to be subjected to when used in a flooring situation.

Durability

The durability of a product or system refers to the ability of that product or system to be used in its intended application for a defined period of time. AAC products have been used in the building industry worldwide for several decades, and continue to be recognized for their performance, particularly durability. The ONE AAC Panel System subjected to normal conditions of environment and use will meet the durability requirements of S1.2.1 of the BCA.

Fire Resistance

AAC materials have exceptional fire resistance and are non-combustible. In the event of fire ONE AAC Panels will not emit any toxic gases or vapours. The ONE AAC Panel System meets the performance requirements of P2.3.1 of the BCA for use as a Floor, providing an 120 minute fire rating from above. (All tests and opinions were conducted by CSIRO, for Copies of Fire Reports or Opinions, contact ONE AAC on 1300 010 222).



Photo courtesy of www.budwell.com

Compliance with the Bush Fire Zone Requirements

The ONE AAC Panel System complies with all six Bush Fire Attack Level categories and is therefore rated as **BAL-FZ (Flame Zone)** for external applications. ONE AAC is a non-combustible material and exceeds an FRL of 30/30/30 when tested from the outside, as per AS3959-2009 Construction of Buildings in Bush Fire-Prone Areas.

Compliant with the Bush Fire Zone Requirements (continued)

The standard defines the construction requirements for external walls as:

- 9.4.1 Walls
Walls shall be one of the following:
- a) Walls made of non-combustible material (e.g. masonry, brick veneer, mud brick, aerated concrete and concrete) with a minimum of 90mm in thicken ss. or
 - b) A system complying with AS1530.8.2 when tested from the outside or
 - c) A system with an FRL of 30/30/30 or –/30/30 when tested from the outsider or
 - d) A combination of any of Items (a), (b) or (c) above

“Reproduced with permission from SAI Global Ltd under Licenses 1204-c05 6”, to purchase the Standard online visit www.saiglobal.com

For a copy of the Fire Test Certificate, contact us on 1300 010 222

Energy Efficiency

The ONE AAC Panel System is able to achieve very good thermal performance (R-Values) i.e. Thermal Mass and Thermal Resistance. The R-Value can be related to the comfort levels within a dwelling, the greater the R- Value the more comfortable the temperature will be within that dwelling. The ONE AAC Panel System easily achieves the Thermal requirements as set out in P2.6.1 of the BCA.

For a copy of the reports for the stated R-Values, contact us on 1300 010 222

Insulation

To increase the R-Value and therefore comfort level, the use of insulation materials is recommended. The insulation should be installed to form a continuous barrier in accordance with the BCA.

Acoustic Performance

The ONE AAC Panel System offers good acoustic performance. To significantly increase the acoustic performance against noise, the use of sound insulation materials is recommended.

- The Bare 50mm ONE AAC Panel has an $R_w = 33$
- The Bare 75mm ONE AAC Panel has an $R_w = 35$

Floor / Ceiling Fire and Acoustic Performance

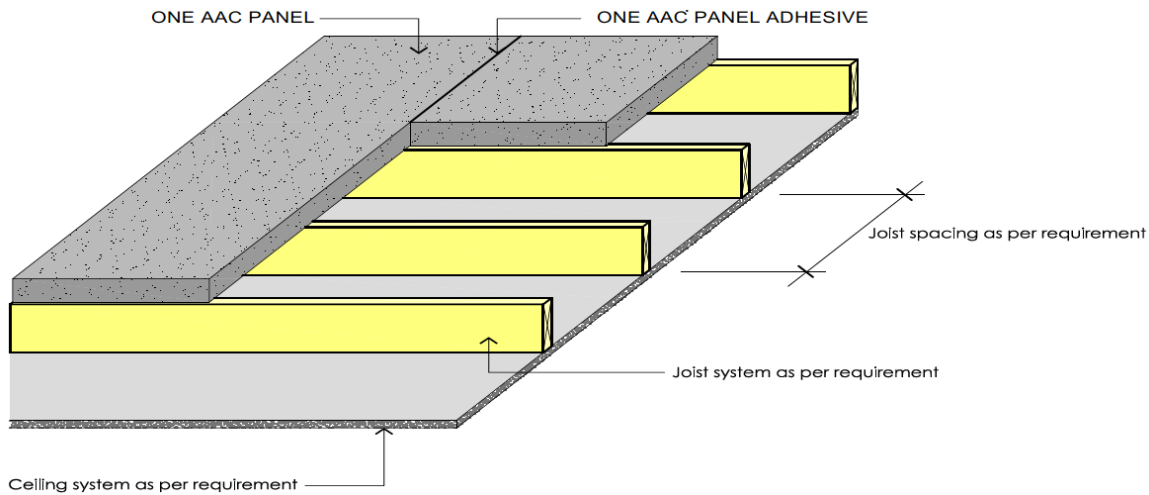

FIRE RATING PERFORMANCE FROM ABOVE AND BELOW - FLOOR / CEILING SYSTEM

Fire Rating From Above & Below (FRL)	Maximum Joist Spacing (mm)	ONE AAC PANEL Thickness (mm)	Ceiling System
120/120/120	450	50	3 layers of 16mm FR PB
	600	75	
90/90/90	450	50	2 Layers of 16mm FR PB or 3 layers of 13mm FR PB
	600	75	
60/60/60	450	50	1 layer of 16mm FR PB
	600	75	

KEY: FR PB = KNAUF FireShield

ACOUSTIC PERFORMANCE - FLOOR / CEILING System A

FLOORING - 75mm thick ONE AAC PANEL:					
FRAME - 140mm deep timber joists with a suspended frame, resilient mounts and furring channels at 450 centres					
CEILING - 1 layer of 13mm Fireshield (applied first) and 1 layer of 16mm Fireshield					
Insulation	Rw	Ctr	Rw + Ctr	Ln,w + Cl (carpet and underlay)	Ln,w + Cl (bare or tiled floor)
50mm Earthwool 11 kg/m ³	60	-3	57	30	58
65mm polyester insulation (ASB3/ TSB3)	60	-3	57	30	58

ACOUSTIC PERFORMANCE - FLOOR / CEILING System B

FLOORING - 75mm thick ONE AAC PANEL:					
FRAME - 140mm deep timber joists with resilient mounts and furring channels at 600 centres					
CEILING - 1 layer of 13mm Fireshield (applied first) and 1 layer of 16mm Fireshield					
Insulation	Rw	Ctr	Rw + Ctr	Ln,w + Cl (carpet and underlay)	Ln,w + Cl (bare or tiled floor)
50mm Earthwool 11 kg/m ³	59	-4	55	32	60
65mm polyester insulation (ASB3/ TSB3)	59	-4	55	32	60

ACOUSTIC PERFORMANCE - FLOOR / CEILING System C

FLOORING - 75mm thick ONE AAC PANEL: FRAME - 140mm deep timber joists with resilient mounts and furring channels at 450 centres CEILING - 2 layers of 16mm Fireshield					
Insulation	Rw	Ctr	Rw + Ctr	Ln,w + Cl (carpet and underlay)	Ln,w + Cl (bare or tiled floor)
50mm Earthwool 11 kg/m ³	59	-4	55	32	60
65mm polyester insulation (ASB3/ TSB3)	59	-4	55	32	60

ACOUSTIC PERFORMANCE - FLOOR / CEILING System D

FLOORING - 75mm thick ONE AAC PANEL: FRAME - 140mm deep timber joists with a suspended frame and furring channels at 450 centres CEILING - 2 layers of 16mm Fireshield					
Insulation	Rw	Ctr	Rw + Ctr	Ln,w + Cl (carpet and underlay)	Ln,w + Cl (bare or tiled floor)
50mm Earthwool 11 kg/m ³	55	-3	52	34	62
65mm polyester insulation (ASB3/ TSB3)	55	-3	52	34	62

ONE AAC Panel System Components

ONE AAC Panels

The ONE AAC Panels are steel reinforced and are manufactured from autoclaved aerated concrete with a dry density of 520kg/m³-560kg/m³. The 50mm and 75mm thick ONE AAC Panels are supplied in a standard length of 2200mm & 1800mm in length for 50mm and 75mm panel respectively and 600mm in width, and have an average dry mass of approx. **40kg/panel for the 50mm thick panels** and approx. **61kg/panel for the 75mm thick panels**.

ONE AAC Panel Fasteners

For 50mm One AAC Panels

- 14-10 x 75mm MP Bugle Head Type 17 screws must be used to fix the panels into timber joists or into steel joists (up to 0.75 BMT)
- 14-10 x 75mm MP Bugle Head Drill Point screws must be used to fix the panels into steel joists greater than 0.75 BMT

For 75mm One AAC Panels

- 14-10 x 100mm MP Bugle Head Type 17 screws must be used to fix the panels into timber joists or into steel joists (up to 0.75 BMT).
- 14-10 x 100mm MP Bugle Head Drill Point screws must be used to fix the panels into steel joists greater than 0.75 BMT

ONE AAC Panel Adhesive

The ONE AAC Panel Adhesive is a polymer modified cement-based adhesive supplied in 20kg bags. It is supplied by ONE AAC, mixed on-site with clean water (see instructions printed ONE AAC bag), and is applied to all edges of the panels (except control joint). ONE AAC Panel Adhesive is also used for minor patching, repairing and stopping over panel joints and screw heads.

ONE AAC Panel - Corrosion Protection Touch Up Paint

When the ONE AAC Panels are cut and the reinforcing steel is exposed to external moisture, it must be treated with the ONE AAC Corrosion Protection Touch Up Paint. It is supplied in 200ml containers. The instructions for use are on the container.

Construction Adhesive

Construction Adhesive such as Max bond, Liquid Nails or similar can be used for adhering and bedding the panels to the joist system. The use of a construction adhesive is optional.

Flexible Sealant

In Non-Fire Rated application, an external grade flexible sealant such as Bostik Seal'N'Flex or equivalent should be used at control joints and around penetrations through the ONE AAC Panels.

Fire Rated Sealant

An external grade fire rated sealant such as Knauf BINDEX, Swirl Engineering Fire Rated Sealant, Fullers FIRESOUND Fire Rated Acoustic Sealant or Bostik FIREBAN ONE Low Modulus Fire Rated Polyurethane Sealant or equivalent must be used in control joints in all fire rated floor / ceiling applications.



System Installation Process

1. Ensure builder has completed the floor joist frame ready for the ONE AAC Panel System
2. Check joist spacing is appropriate for the length of panels being used.
 - a. For the 50mm x 2200mm long panels the joist set out should be 440mm (edge to center of first joist spacing and then center to center after that).
 - b. For the 75mm x 1800mm long panels the joist set can set out at either 450mm (edge to center of first joist spacing and then center to center after that) or at 600mm (edge to center of first joist spacing and then center to center after that).
3. A minimum joist width of 45mm is required, but 63mm or greater is preferred.
4. Apply construction adhesive to joist area of first panel position, (optional)
5. Place panel over joist in the required position.
6. Screw panel to joist using the correct length screw
 - a. 2 screws per joist per panel width
 - b. Min 50mm from panel edges
7. Apply ONE AAC panel adhesive to panel edges where abutment of panels occurs. The use of a construction adhesive to bond these joints is permitted in Non-Fire Rated applications.
8. Repeat the process from item 4 above until complete, ensuring a stretcher bond pattern - staggered panel layout.
9. Panels butt joints can be joined on a joist, the screw fixing at these locations can be shared by both panels, i.e. screws fixed into the panel butt joint, or angled a minimum of 50mm away from the joint.
10. Panels can be joined Off Joist, as long as each panel is fixed to a minimum of 2 joists. The off joist joint must be back blocked using a minimum of a 90mm x 45mm solid timber or 0.75BMT steel stud/channel as back blocking.
11. The combination of 75mm and 50mm panel or compressed fibre cement sheeting in the wet areas will provide a stepdown to the wet area if required.
12. Occasionally the thickness of the panel will need to be reduced to ensure that a flat/level floor is maintained. The underside of the floor panel may be notched to accommodate odd height joists or steel support beams, or sanded from the top face of the panel to ensure the panel surface is flat/level. The thickness that can be removed is as follows:
 - a. A maximum of 25mm for 75mm thick ONE AAC Panel on 450mm joist centers
 - b. A maximum of 15mm for 75mm thick ONE AAC Panel on 600mm joist centers
 - c. A maximum of 10mm for 50mm thick ONE AAC Panel on 450mm joist centers



Installation Process

Ensure joist framework is completed to accept panel

Joist to be set out at 440mm, 450mm or 600mm centers

Minimum joist width of 45mm is required (63mm preferred)

90mm joists shown

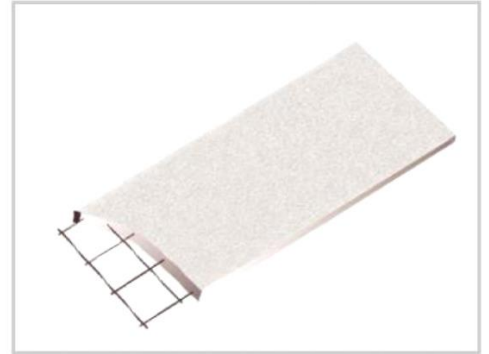
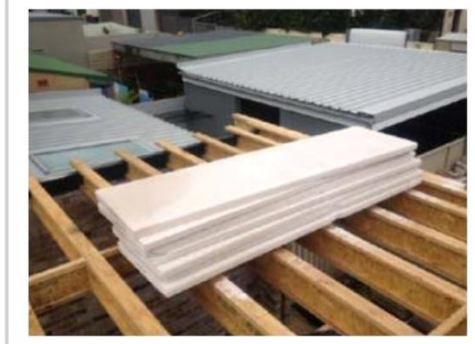

Apply construction adhesive to joists (optional)

Position panel over construction adhesive

Fix panel to joists using the appropriate length panel fasteners

2 fasteners per joist

Min. 50mm from panel edges

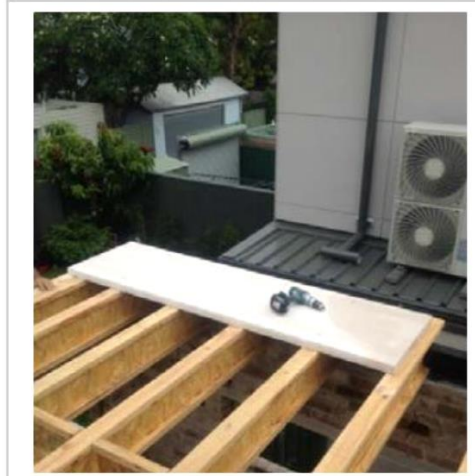

Apply AAC Panel Adhesive to all panel joints.

If fire rating is not required, the use of construction adhesive for bonding panel joints is permitted.



Apply construction adhesive to the next lot of joists to accept the next panel length (optional)

Butt panels end to end

Ensure panels are aligned

Screw panel to joists

Fasteners at butt joints can be shared by both panels as shown or angled 50mm away from panel joint.

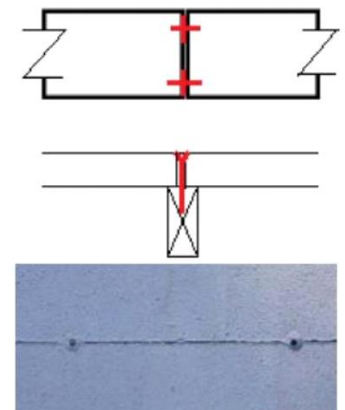
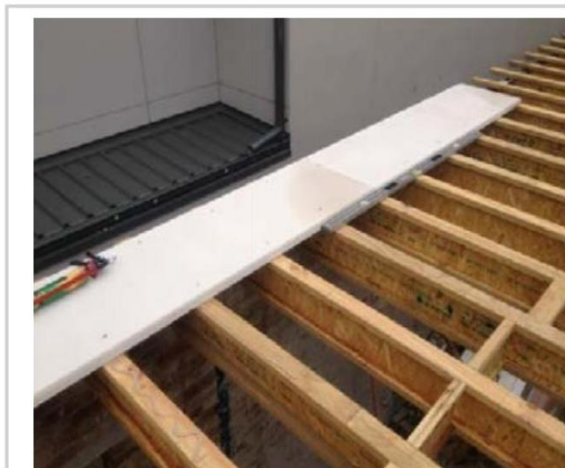

Apply adhesive to all panel edges and joints

Start a new row of panels with a minimum of 1 joist spacing stagger



Continue panel installation in the "stretcher bond" staggered panel layout



Continue panel installation until the floor area is complete.



Combine AAC Panel with FC flooring to create step-down for wet areas



Basic Tools Required When Working With AAC

The basic tools required when working with AAC are typically used by the carpentry and rendering trades and are readily available and relatively inexpensive when it comes to the complete set up for working with AAC.

Some of the tools required to make the job easy are identified below:

- ◆ Personal Protective Equipment
 - High Visibility Work Wear, Steel Cap Boots
 - Gloves, Dust Mask, Goggles, Hearing Protection
- ◆ Standard Contractor Tools
 - Hammer, Nail Bag, Tape, Pencil, Level
 - Tin Snips, Chisels, Knife
 - Electric Leads and Power Box
- ◆ Power Saw
 - Preferably Dustless
 - Fitted with a Diamond Blade
- ◆ Vacuum
- ◆ Power drill / Mixing Drill / Mixing Buckets
- ◆ Cordless Drills and Drive Bits
- ◆ Grinder / Reciprocator Saw
- ◆ Adhesive Trowel
- ◆ Hawk and Steel Trowel
- ◆ Nail or Staple Gun
- ◆ Sanding Float / Rasp



Delivery Storage & Handling

Delivery

One AAC Panels are delivered in packs of 15 panels per pack for 50mm Panel and 10 panels per pack for 75mm Panel. For transport and lifting purposes the wet mass of the panels should be used. Each pack has a wet mass of approximately 900kg including the packaging. Packs shall be unloaded or moved with approved lifting devices. To minimise double handling and save time the packs should be unloaded as close as possible to the installation area. ONE AAC Panel packs should only be stacked one pack high (on site) and properly supported on level ground. If any of the packs are to be placed on any part of the structure, always consult the project engineer as to the adequacy of the structure before doing so.

Storage

All ONE AAC material should be kept dry and preferably under cover, all care should be taken to avoid damage to the face, ends and edges of the panels. When ONE AAC Panels are stored outside they must be off the ground and protected from the weather.

Manual Handling

Physical manual handling of ONE AAC Panels around the work site should be kept to a minimum, always carry the panels on edge, and support the weight by a two man lift procedure. Where the manual handling becomes excessive with respect to distance from the installation area, ONE AAC recommends the use of trolleys and/or other mechanical devices.

Occupational Health & Safety (OH&S)

ONE AAC Panels, along with all clay, concrete and quarry products contain Crystal line Silica, or Silica Dust. Prolonged exposure to Silica dust without the correct Personal Protection Equipment can be harmful and potentially cause life threatening health hazards such as bronchitis, silicosis and lung cancer.

The ONE AAC Panel itself does not cause health problems, however when cutting, drilling, chasing, sanding, etc., the exposure to high volumes of dust is increased, which increases the potential for health problems to occur, unless standard precautionary measures are taken. Repeatedly breathing in high volumes of dust over many years, may lead to health problems.

It is most unlikely to breath in high volumes of fine silica dust when stacking, loading or laying panels, however when cutting, drilling, chasing, sanding, etc., it is imperative that safety masks, hearing and eye protection is worn. Ensure the mask fits properly and is approved for use with dust. Protective clothing should also be worn e.g. high visibility long sleeve shirt and long pants. These should be washed often and not in the same wash as other clothes.

The site should be cleaned of dust every day, and when using power tools these should be tagged for use as required and be fitted with efficient and well maintained dust extraction devices. The ONE AAC Panel Installer on site has a responsibility to inform all employees of these Health and Safety requirements under the Occupational Health and Safety Act.

Personal Protective Equipment (PPE)

When working with AAC, ONE AAC recommends (as a minimum) that the following PPE is worn:

- ◆ P1 or P2 Dust masks – complying with AS/NZS1715 and AS/NZS1716
- ◆ Glasses / Goggles - complying with AS1336
- ◆ Ear Plugs / Ear Muffs – Class 5
- ◆ Gloves, long sleeve shirt and pants – to prevent possible skin irritation and skin cancer from working outdoors
- ◆ Steel Cap Boots

Cutting

ONE AAC Panels can be easily cut, drilled, or chased using power or hand tools. When working with ONE AAC Panels ensure that the PPE as previously described is worn. As an added measure of containing the dust when working with AAC products, ONE AAC recommends the use of dust extraction equipment.

ONE AAC Panel makes cutting easier for the installer, as they are delivered to site flat packed, essentially each pack of panel is its own cutting bench, simply adjust the depth of the saw blade to the thickness of the panel, and cut the required panels before removing it from the pack. Any exposed reinforcement during cutting must be coated with the ONE AAC Panel Corrosion Protection Touch Up Paint. For a copy of the full range of ONE AAC Panel MSDS sheets, visit the website; www.oneaac.com.au

Hazardous Materials

With reference to the BCA, regarding Hazardous Building Materials, AAC Panels are non-hazardous, provided that all safety precautions included in this literature are adhered to.

Warranty & Guarantee

ONE AAC Panels are quality building products, and come with the following Warranty and Guarantee:

Warranty

ONE AAC Panels and associated materials, when installed as exterior wall cladding, are warranted for a minimum of **15 years** (from the date of purchase), not only meeting, but exceeding the **7 year** requirement outlined in the BCA and the relevant Australian Standards. The ONE AAC Panel products are designed to have a life span significantly in excess of this minimum period.

Guaranteed

ONE AAC Panel Autoclaved Aerated Concrete products are guaranteed to be free of defect in material and manufacture.

For further details or information on the engineering, design and construction with the ONE AAC Panel System, please contact our sales or technical professionals on 1300 010 222 or visit our website: www.oneaac.com.au to obtain the latest Design & Installation Manuals.

FLOOR EDGE DETAILS

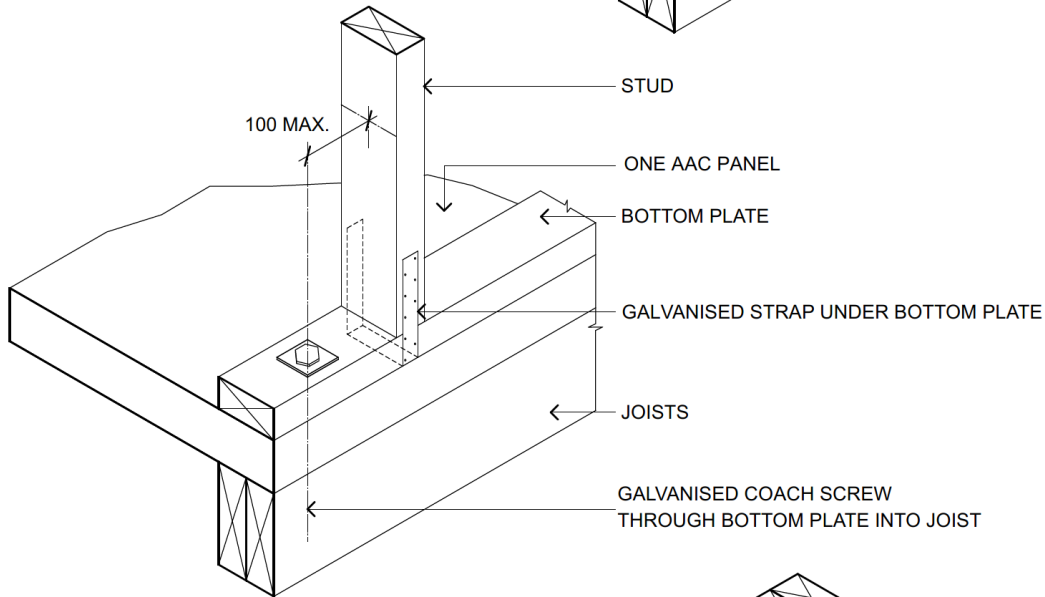
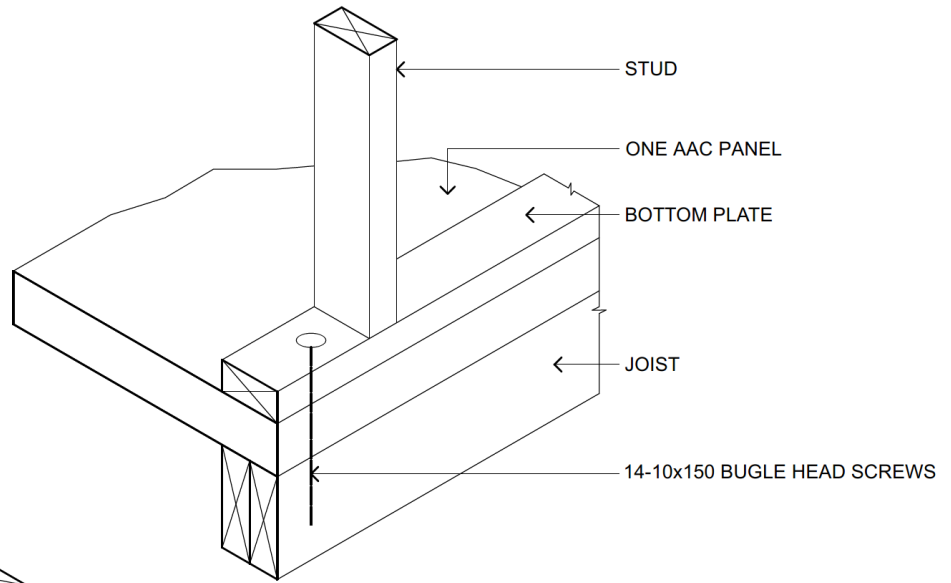

**BRACED WALL FIXING
OPTION 1**

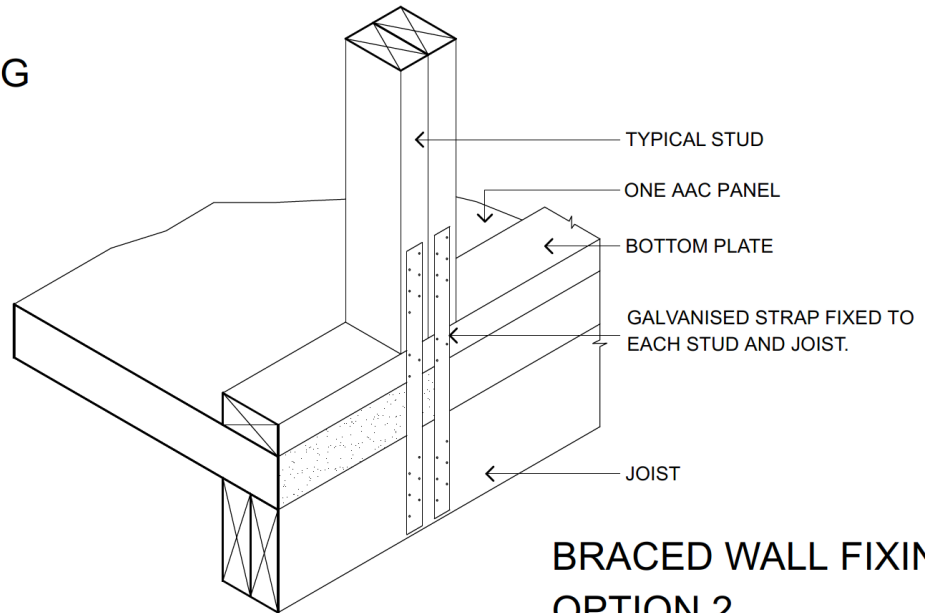

**BRACED WALL FIXING
OPTION 2**

FLOOR FIXING DETAILS

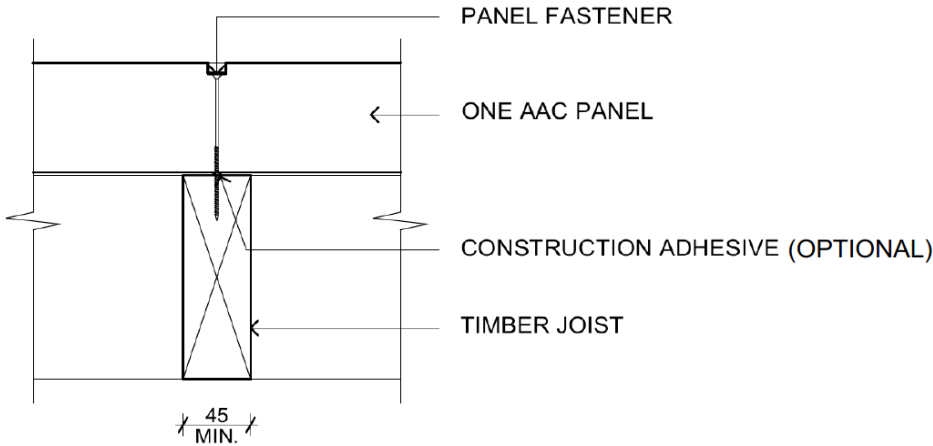

TIMBER JOIST FIXING

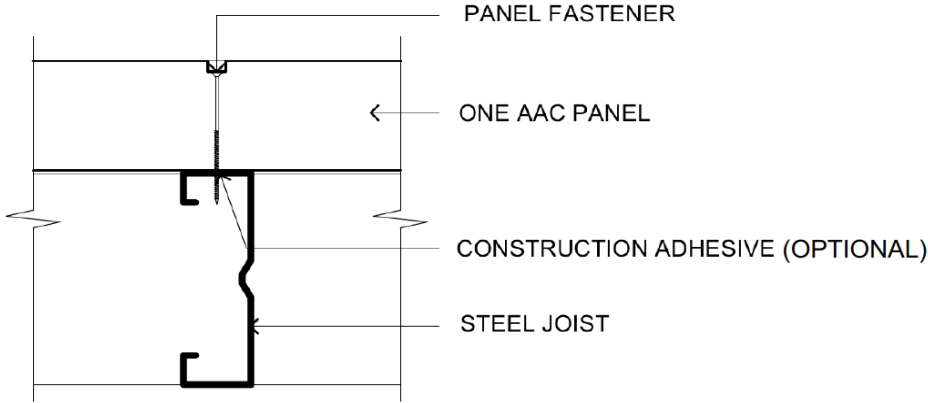

STEEL JOIST FIXING

FLOOR FIXING DETAILS

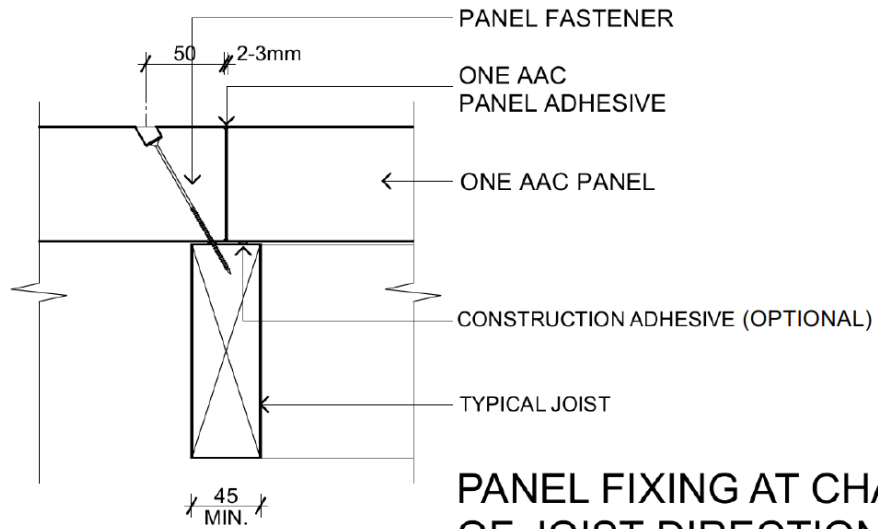

PANEL FIXING AT CHANGE OF JOIST DIRECTION

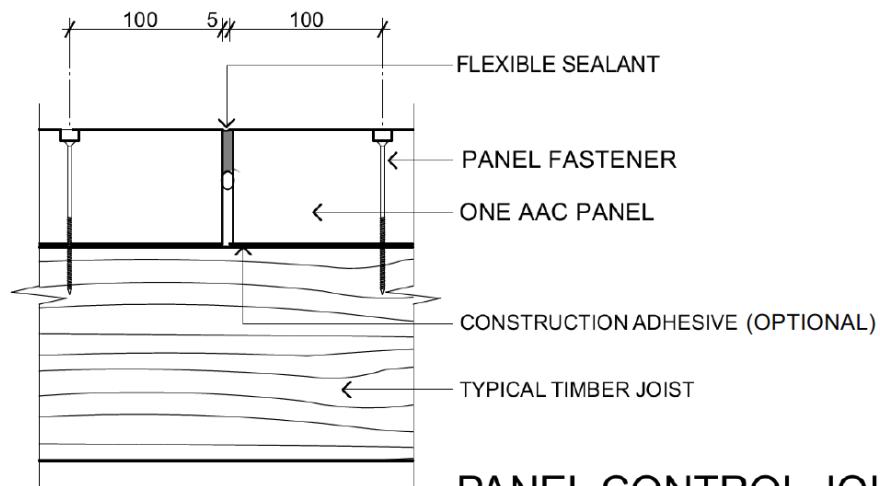

PANEL CONTROL JOINT

FLOOR FIXING DETAILS

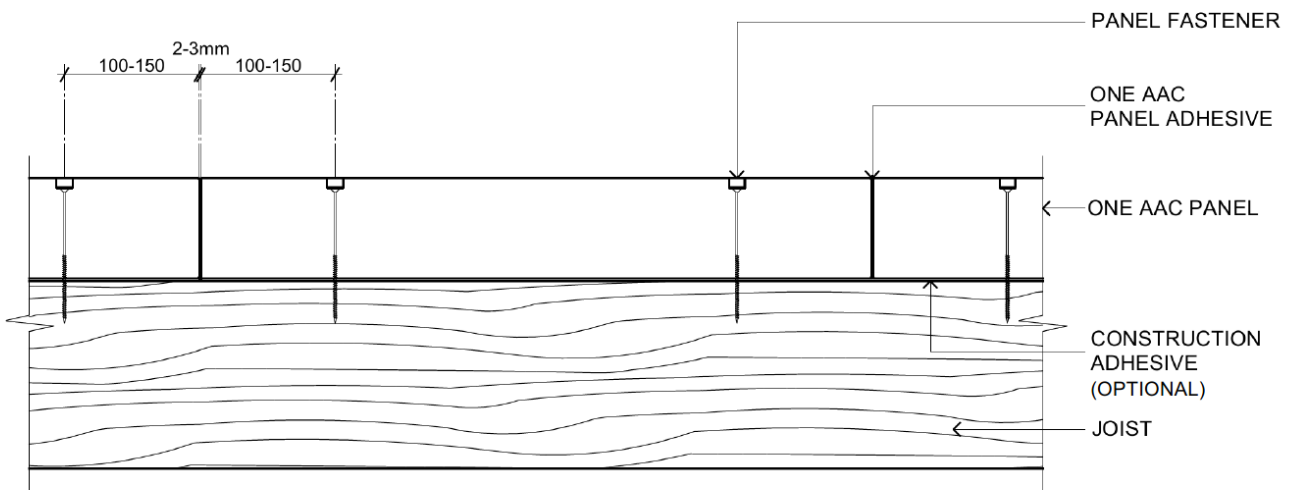
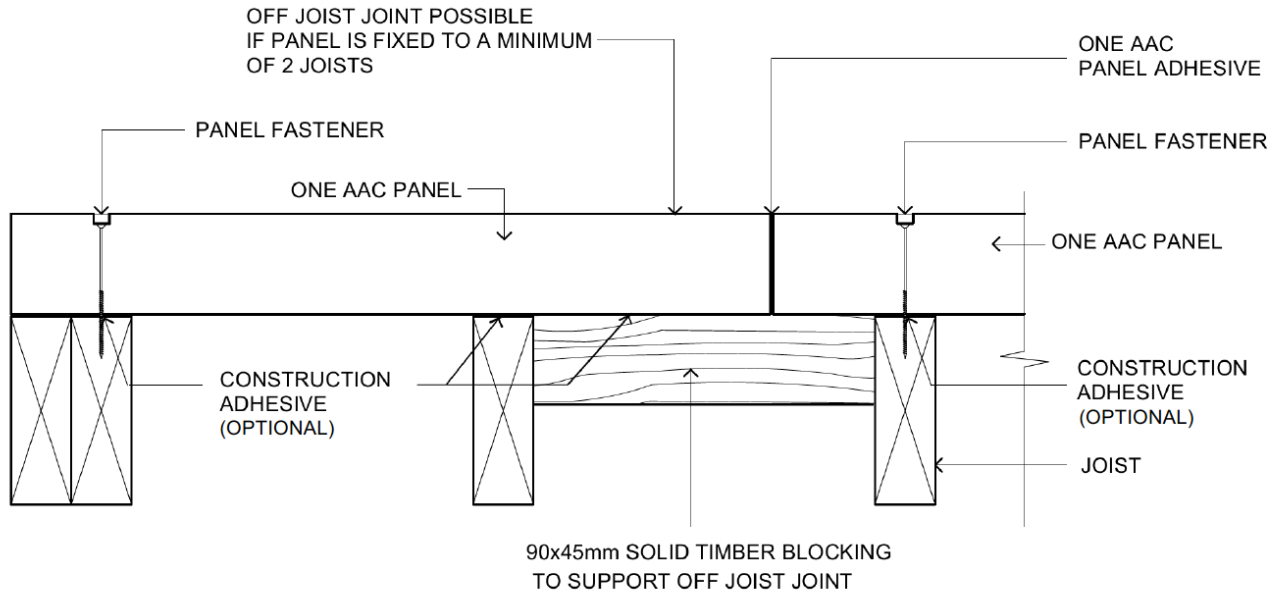

PANEL FIXING ALONG AND ACROSS JOIST DETAILS

INTERNAL WALL FIXING

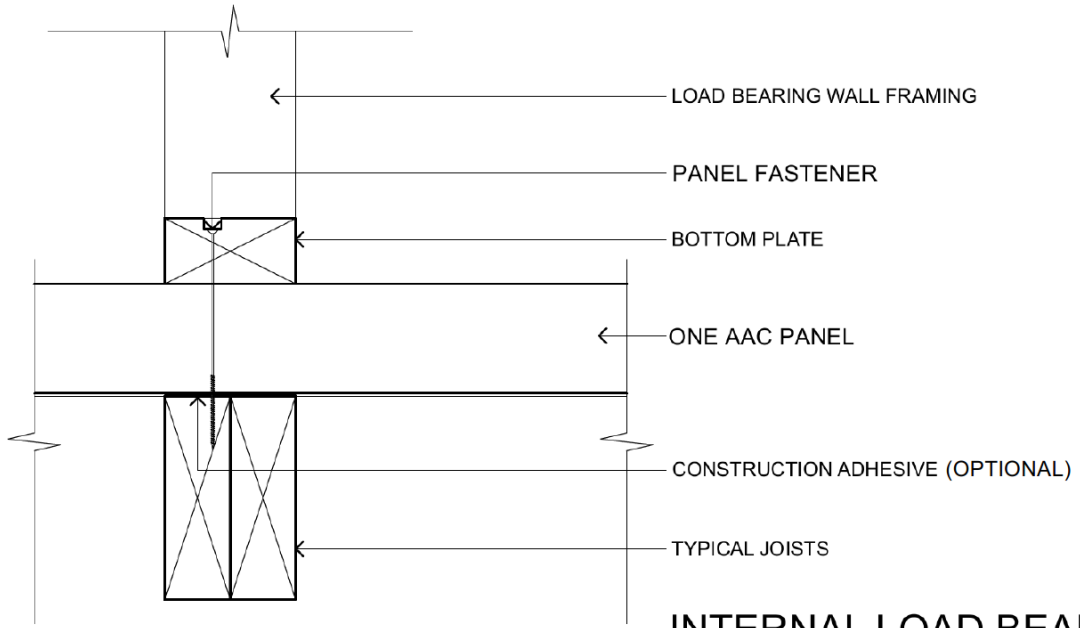

INTERNAL LOAD BEARING WALL FIXING

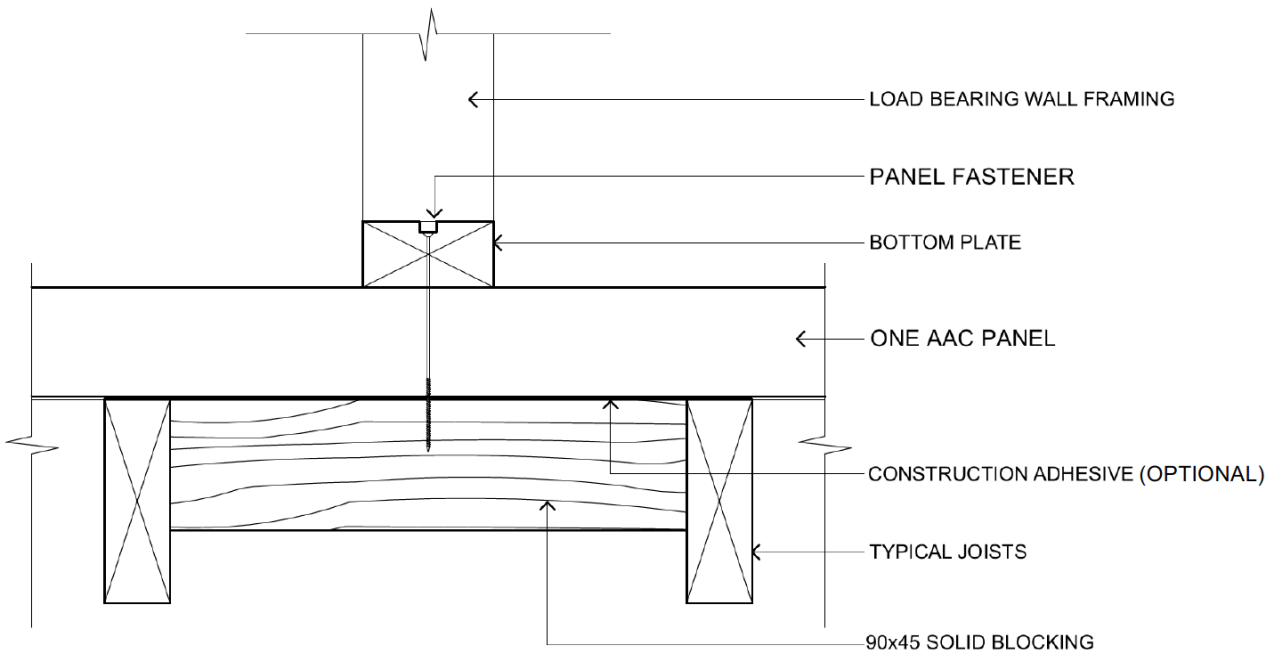

INTERNAL LOAD BEARING WALL FIXING

PENETRATION DETAILS

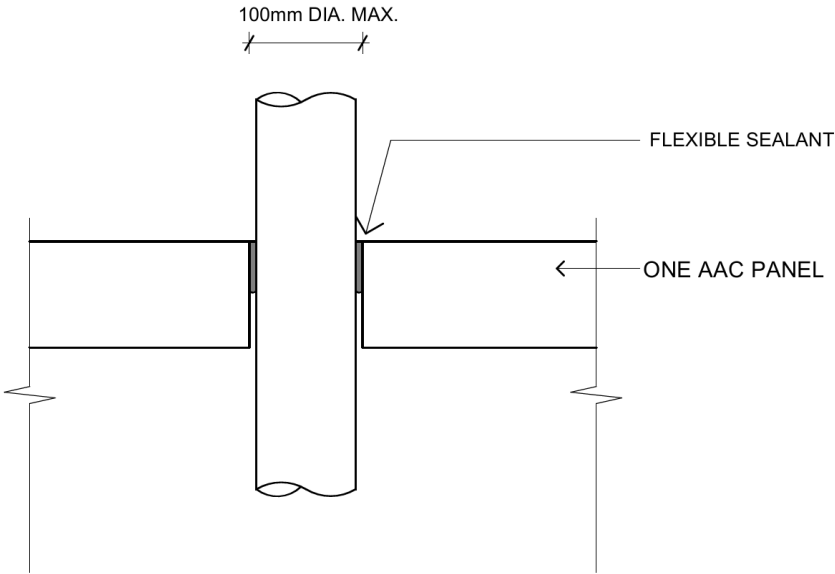

PENETRATIONS LESS THAN 100mm

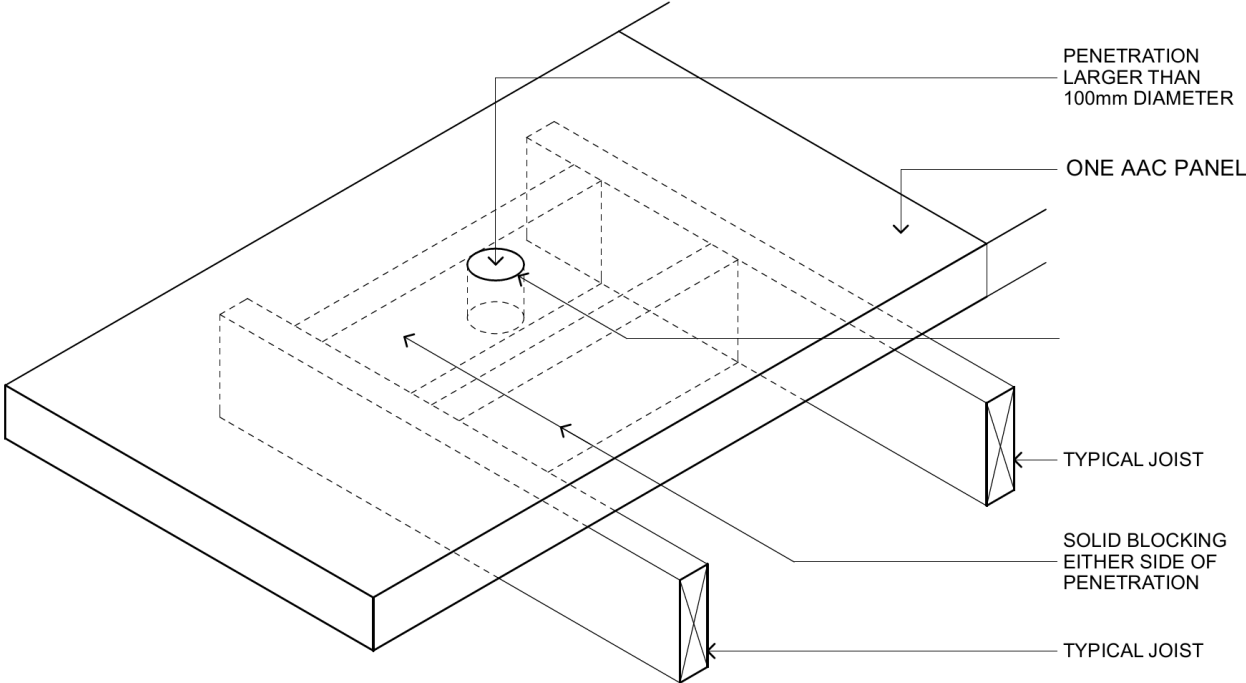

PENETRATIONS GREATER THAN 100mm

PANEL LAYOUTS

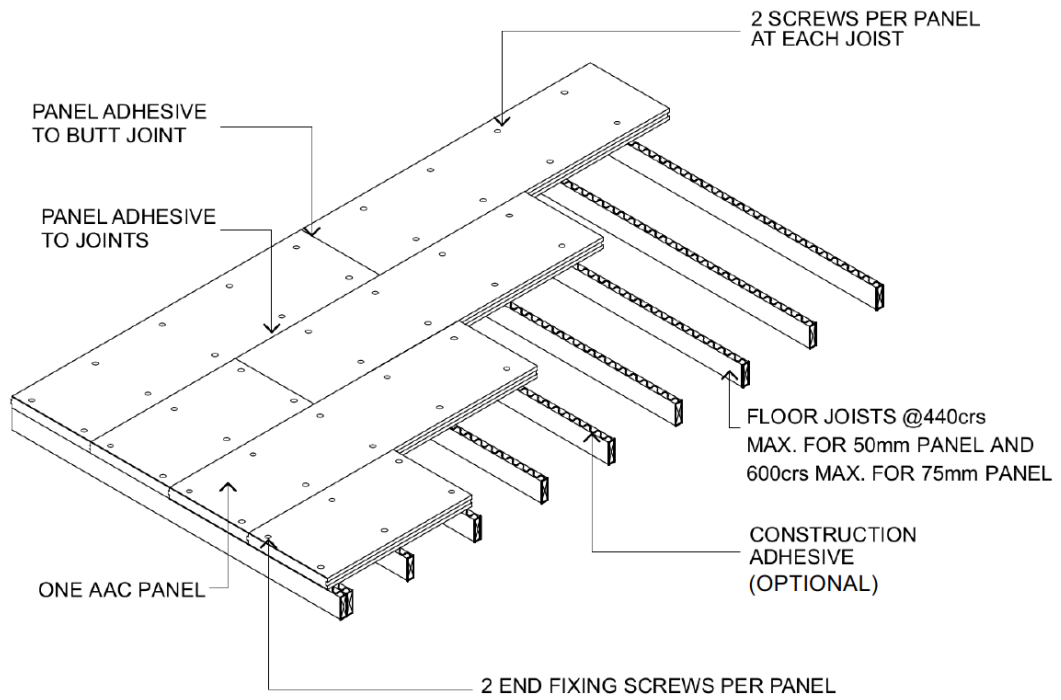

TYPICAL PANEL LAYOUT

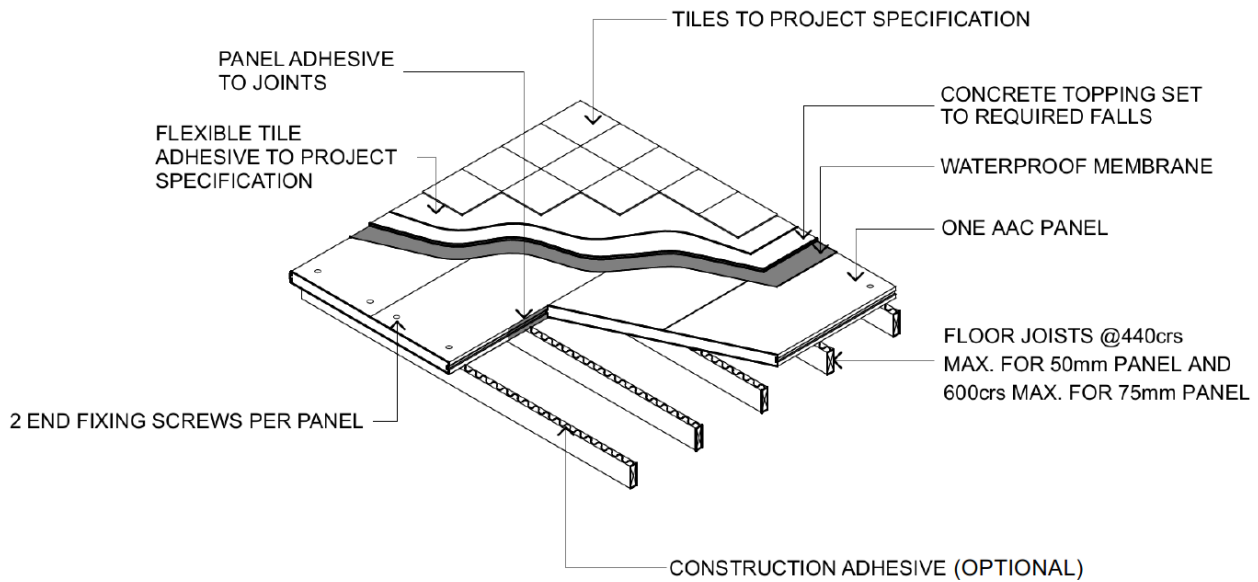

CREATING FALLS ON PANELS



Certificate of Conformity

Certification Body:



Global-Mark Pty Ltd,
Suite 4,07,
32 Delhi Road,
North Ryde NSW
2113, Australia
Ph: +61 2 9886 0222
www.global-mark.com.au

Certificate Holder:

ONE AAC PANEL
485 Campbelltown Rd
Denham Court NSW
2565
Ph: 1300 010 222
www.oneaac.com.au

Certificate number: CM30031 Rev 3	
THIS TO CERTIFY THAT	
ONE AAC PANEL	
<p>Type and/or use of product: ONE AAC PANELS are reinforced AAC (Autoclaved Aerated Concrete) Panels for use in all building types (BCA Vol 1 & 2), in the following applications:</p> <ul style="list-style-type: none"> • Fire, thermal & acoustic rated cladding for load-bearing, single leaf external timber or steel framed walls. • Fire, thermal & acoustic rated cladding for load-bearing, dual zero boundary external timber or steel framed walls. • Fire barrier with thermal & acoustic rating between timber or steel framing of separate occupancies in residential apartments. • Thermal & acoustic rated flooring panels for timber or steel framed floor structures. 	<p>Description of product: Reinforced Autoclaved Aerated Concrete (AAC) Panels in the following sizes:</p> <ul style="list-style-type: none"> • 50mm thickness (2,200mm, 2,400mm & 2,550mm length x 600mm width), and • 75mm thickness (1,800mm, 2,200mm, 2,400mm, 2,700mm, 2,850mm, 3,000mm & 3,300mm lengths x 600mm width)
COMPLIES WITH THE FOLLOWING BCA PROVISIONS AND STATE OR TERRITORY VARIATION(S)	
BCA 2022	
Volume One	
Performance Requirement(s)	Volume Two and Housing Provisions (HP)
B1P1	H1P1
B1P2	H1D7 (4)(a)
Deemed-to-Satisfy Provision(s):	Wall cladding
B1D4 (b)(ii)	Structural stability and resistance to actions
B1D4 (b)(ii)	Determination of structural resistance of materials and forms of construction

Scope of certification: The CodeMark Scheme is a building product certification scheme. The rules of the Scheme are available at the ABCB website www.abcb.gov.au. This Certificate of Conformity is to confirm that the relevant requirements of the Building Code of Australia (BCA) as claimed against have been met. The responsibility for the product performance and its fitness for the intended use remain with the certificate holder. The certification is not transferrable to a manufacturer not listed on Appendix A of this certificate.

Disclaimer: The Scheme Owner, Scheme Administrator and Scheme Accreditation Body do not make any representations, warranties or guarantees, and accept no legal liability whatsoever arising from or connected to, the accuracy, reliability, currency or completeness of any material contained within this certificate; and the Scheme Owner, Scheme Administrator and Scheme Accreditation Body disclaim to the extent permitted by law, all liability (including negligence) for claims of losses, expenses, damages and costs arising as a result of the use of the product(s) referred to in this certificate.

The purpose of Global-Mark construction site audits is to confirm the practicability of installing the product; and to confirm the appropriateness and accuracy of installation instructions. In placing the CodeMark mark on the product/system, the certificate holder makes a declaration of compliance with the certification standard(s) and confirms that the product is identical to the product certified herein. In issuing this Certificate of Approval Global-Mark has relied on the expertise of external bodies (laboratories, and technical experts).

Herve Michoux

Herve Michoux
Global-Mark Managing Director

P. Gardner

Peter Gardner
Unrestricted Building Certifier

Date of issue: 01/05/2023

Date of expiry: 17/05/2025



Certificate number: CM30031

This certificate is only valid when reproduced in its entirety.

Page 1 of 10

C2D10	Non-combustible material			
C2D2	Fire resistance and stability – Type of construction required	H3D3	Fire Separation of external walls	
Specification 1	Fire-resistance of building elements	Specification 1	Fire-resistance of building elements	
Specification 5	Fire resisting construction	HP 9.2.3	Construction of external walls	
		HP 9.3.1	Fire Protection of separating walls	
		HP 9.3.4	Fire Protection – Horizontal projections	
		HP 9.4.1	Fire Protection of garage top dwellings - Walls	
F1D6	Damp-proofing			
F3D5 (1)(b)	Weatherproofing – Wall cladding	H2D6 (4)	Weatherproofing – Roof and wall cladding	
F7D3	Determination of airborne sound insulation ratings	HP 10.7.2	Determination of airborne sound insulation ratings	
F7D4	Determination of impact sound insulation ratings			
F7D5	Sound insulation rating of floors			
F7D6	Sound insulation rating of walls	HP 10.7.1	Sound insulation requirements	
		HP 10.7.3	Construction of sound insulated walls	
G5D3	Construction in bushfire prone areas – Protection of residential buildings	H7D4 (2)(a)	Construction in bushfire prone areas	
G5D4	Construction in bushfire prone areas – Protection of certain Class 9 buildings			
J4D6	Building fabric – Walls and glazing	HP 13.2.5	Building fabric – External walls	
NT B1D4 (b)(ii)	Structural resistance	WA H1D7 (4)(a)	Wall cladding	
QLD B1D4 (b)(ii)	Structural resistance			
WA B1D4 (b)(ii)	Structural resistance	HP NSW 9.4.1	Fire Protection of garage top dwellings – Walls	
SA F1D6(2)	Damp-proofing	HP NSW 9.4.3	Fire Protection of garage top dwellings – Separating floors	
NT Part F7	Sound transmission & insulation	HP NT 10.7	Sound insulation	
NSW G5D3	Construction in bushfire prone areas – Protection of residential buildings	NSW H7D4 (2)(a)	Construction in bushfire prone areas	
NSW G5D4	Construction in bushfire prone areas – Protection of certain Class 9 buildings			

State or territory variation(s):

			Construction in bushfire prone areas – Protection of certain Class 9 buildings		
	VIC G5D4		Building fabric – Walls and glazing	HP NSW 13.2.5	Energy efficiency – External walls
	NSW J4D6		Energy efficiency: Class 2 or Class 4 part of a building (up to V3 BASIX dwellings & BASIX Alterations and additions) – NCC 2019 A1 NSW Section J	NSW H6	Energy efficiency: Up to V3 BASIX dwellings & BASIX Alterations and additions – NCC 2019 A1 NSW 2.6
	NSW Section J		Class 2 or Class 4 part of a building (V4 or later BASIX dwellings) plus Class 3, 5, 6, 7, 8 & 9 buildings – NCC 2022 Section J		V4 or later BASIX dwellings – NCC 2022 NSW Part H6
	NT Part J4		Building Fabric	NT Part H6	Energy efficiency
				HP NT 13.2.5	Energy efficiency - building fabric – External walls
	TAS Section J		Energy Efficiency – Class 2 and Class 4 part of a building – NCC 2019 (A1) Section J	TAS Part H6	Energy efficiency – NCC 2019 (A1) 2.6
				HP TAS 13.2	Energy Efficiency – NCC 2019 3.12

SUBJECT TO THE FOLLOWING LIMITATIONS AND CONDITIONS AND THE PRODUCT TECHNICAL DATA IN APPENDIX A AND EVALUATION STATEMENTS IN APPENDIX B

	Limitations and conditions:				Building classification/s:
	Volume 1 – B1P1	&	Volume 2 – H1P1		1, 2, 3, 4, 5, 6, 7, 8, 9 & 10
	The wall systems as described have maximum design wind load limits documented within the relevant ONE AAC Design & Installation Manuals (refer Appendix B2). Wind load limits, construction details and fixing methods must follow the relevant details contained within the engineering detail sections of the relevant ONE AAC Design & Installation Manuals, refer Appendix B2.				
	Volume 1 – B1P1 (2)(e), (f) & (i)	&	Volume 2 – H1P1 (2)(e), (f) & (i)		1, 2, 3, 4, 5, 6, 7, 8, 9 & 10
	Snow, liquid pressure and earth pressure actions are excluded.				
	Volume 1 – B1P4	&	Volume 2 – H1P2		1, 2, 3, 4, 5, 6, 7, 8, 9 & 10
	Compliance for flood hazard areas is excluded.				
	Volume 1 – C2D10				2, 3, 4, 5, 6, 7, 8 & 9
	Non-combustibility relates to AAC material only.				
	This certification is based upon the system being installed using components & accessories as specified in the relevant ONE AAC Design & Installation Manuals, refer Appendix B2. Substitution of wall system components &/or accessories may be permitted, however the general performance specifications of components &/or accessories must be maintained for this certificate to remain valid.				
	Volume 1 – C2D10 (1)(a)				2, 3, 4, 5, 6, 7, 8 & 9

	<p>In a building required to be of Type A or B construction, construction elements and their components must be non-combustible for all external walls, common walls and non-loadbearing internal walls that are required to be fire-resisting.</p> <p>Volume 1 – C2D10 (6) In external wall applications, flexible sarking membrane (wall wrap) materials shall be installed in accordance with the relevant ONE AAC Design & Installation Manuals, refer Appendix B2.</p> <p>Volume 1 – Specification 1 & Volume 2 – Specification 1 & Housing Provisions – 9.2.3, 9.3.1, 9.3.4, 9.4.1, NSW 9.4.1 & NSW 9.4.3 Refer to relevant construction options, details & conditions, included in the relevant ONE AAC Design & Installation Manuals, refer Appendix B2.</p> <ul style="list-style-type: none"> External wall FRLs of up to 120/120/90 or 120/120/120 are achievable (refer construction options). Intertency wall FRLs of 60/60/60, 90/90/90 or 120/120/120 are achievable (refer construction options). Dual Zero Boundary wall FRLs of 60/60/60 apply. <p>Volume 1 – Specification 1 & Volume 2 – Specification 1 Compliance for Fire resistance of the ONE AAC flooring system is excluded from this certificate.</p> <p>Volume 1 – G5D3 In designated Bushfire prone areas, when the building is constructed in accordance with AS3959:2018 including Amendment 1 & 2, ONE AAC Panels are permitted for use as external wall cladding in buildings subject to Bushfire Attack Level in all zones up to and including BAL-FZ.</p> <p>Volume 2 – H7D4 In designated Bushfire prone areas, when the building is constructed in accordance with AS3959:2018 including Amendments 1 & 2, or NASH Standard – Steel Framed Construction in Bushfire Areas, ONE AAC Panels are permitted for use in buildings subject to Bushfire Attack Level up to & including BAL-FZ.</p> <p>Volume 1 – G5D4 In designated bushfire prone areas when the building is constructed in accordance with Specification 43, ONE AAC Panels are permitted for use only in buildings subject to Bushfire Attack Level not exceeding BAL-12.5. Construction in BAL-19, BAL-29, BAL-40 and BAL-FZ fall outside the scope of application of the clause.</p> <p>Volume 1 – J4D6 & NSW J4D6 & Housing Provisions – 13.2.5 & NT 13.2.5 The wall system contributes towards the Total wall system U or R value, which is to be determined in accordance with Volume 1 – J4D6 & Housing Provisions – 13.2.5. Insulation shall be included within the wall system, as outlined in the relevant Design & Installation Manual & according to project specifications.</p> <p>Volume 1 – NSW G5D3 In designated bushfire prone areas, subject to Bushfire Attack Level BAL-LOW, BAL-12.5, BAL-19 and BAL-29, determined in accordance with the Planning for Bush Fire Protection 2019 including addendum November 2022, when the building is constructed in accordance with AS3959: 2018</p>	<p>2, 3, 4, 5, 6, 7, 8 & 9</p> <p>1, 2, 3, 4, 5, 6, 7, 8, 9 & 10</p> <p>1, 2, 3, 4, 5, 6, 7, 8, 9 & 10</p> <p>Class 2, 3 and Class 10a building or decks immediately adjacent or connected to Class 2 or 3 building</p> <p>Class 1 & 10a building or deck associated with a Class 1 building</p> <p>Class 9a, 9b, 9c and Class 10a buildings or decks immediately adjacent or connected to Class 9a, 9b or 9c buildings</p> <p>1, 2, 3, 4, 5, 6, 7, 8, 9 & 10</p> <p>2, 3, Class 4 part of a building & 10a building or deck immediately</p>
--	--	--

<p>including Amendments 1 & 2, except as modified by Planning for Bush Fire Protection 2019 including addendum November 2022, ONE AAC Panels are permitted for use.</p> <p>The compliance assessment of the certified system is limited to sections 7.5 and 8.3.2 of the Planning for Bush Fire Protection 2019, including addendum November 2022.</p> <p>Site specific conditions arising from:</p> <ul style="list-style-type: none"> - the development consent following consultation with the NSW Rural Fire Service under section 4.14 of the Environmental Planning and Assessment Act 1979 if required, or - the development consent with a bushfire safety authority issued under section 100B of the Rural Fires Act 1997 for the purposes of integrated development <p>have not been considered for the compliance assessment.</p> <p>The Planning for Bush Fire Protection 2019 including addendum November 2022 requires a performance-based application in bushfire prone areas subject to Bushfire Attack BAL-40 and BAL-FZ. Construction in NSW's bushfire prone areas subject to Bushfire Attack BAL-40 and BAL-FZ have not been considered in this assessment.</p>	<p>adjacent or connected to building class 2, 3 or Class 4 part of a building</p>
<p>Volume 2 – NSW H7D4 (2)</p> <p>In designated bushfire prone areas subject to Bushfire Attack Levels BAL-LOW, BAL-12.5, BAL-19 and BAL-29, determined in accordance with the Planning for Bush Fire Protection 2019 including addendum November 2022, when the building is constructed in accordance with:</p> <ul style="list-style-type: none"> - AS3959: 2018 including Amendments 1 & 2 except as modified by Planning for Bush Fire Protection 2019 including addendum November 2022, or - NASH Standard – Steel Framed Construction in Bushfire Area Except as amended by the Planning for Bush Fire Protection 2019 including addendum November 2022, <p>ONE AAC Panels are permitted for use.</p> <p>The compliance assessment of the certified system is limited to sections 7.5 and 8.3.2 of the Planning for Bush Fire Protection 2019 including addendum November 2022.</p> <p>Site specific conditions arising from:</p> <ul style="list-style-type: none"> - the development consent following consultation with the NSW Rural Fire Service under section 4.14 of the Environmental Planning and Assessment Act 1979 if required, or - the development consent with a bushfire safety authority issued under section 100B of the Rural Fires Act 1997 for the purposes of integrated development <p>have not been considered for the compliance assessment.</p> <p>The Planning for Bush Fire Protection 2019 including addendum November 2022 requires a performance-based application in bushfire prone areas subject to Bushfire Attack BAL-40 & BAL-FZ. Construction in NSW's bushfire prone areas subject to Bushfire Attack BAL-40 & BAL-FZ have not been considered in this assessment.</p> <p>Volume 1 – NSW G5D4</p> <p>In designated bushfire prone areas subject to Bushfire Attack Levels not exceeding BAL-12.5, determined in accordance with the Planning for Bush Fire Protection 2019 including addendum November 2022, ONE AAC Panels are permitted for use when the building is constructed in accordance with:</p>	<p>Class 1 & 10a building or deck associated with a Class 1 building</p>
	<p>Class 9 building that is a special fire protection purpose; and a Class 10a building or deck immediately</p>



Certificate of Conformity

<p>a) For class 9 buildings, Specification 43 except as modified by Planning for Bush Fire Protection 2019 including addendum November 2022, or</p> <p>b) For class 10a buildings or decks, AS3959: 2018 including Amendments 1 & 2 except as modified by Planning for Bush Fire Protection 2019 including addendum November 2022 and S43C13,</p> <p>The compliance assessment of the certified system is limited to sections 7.5 and 8.3.2 of Planning for Bush Fire Protection 2019 including addendum November 2022.</p> <p>Site specific conditions arising from the development consent with a bushfire safety authority issued under section 100B of the Rural Fires Act 1997 for the purposes of integrated development are site specific and have not been considered for the compliance assessment.</p> <p>Construction in BAL-19, BAL-29, BAL-40 and BAL-FZ fall outside the scope of application of the clause.</p>	<p>adjacent or connected to such building</p>
<p>Volume 1 – VIC G5D4</p> <p>In designated bushfire prone areas when the building is constructed in accordance with Specification 43, ONE AAC Panels are permitted for use only in buildings subject to Bushfire Attack Level not exceeding BAL-12.5.</p> <p>Construction in BAL-19, BAL-29, BAL-40 and BAL-FZ fall outside the scope of application of the clause.</p>	<p>Class 4 part of a building, Class 9a, 9b, 9c and Class 10a buildings or decks immediately adjacent or connected to Class 4 parts, Class 9a, 9b or 9c buildings</p>
<p>Volume 1 – NSW J4D6, NT Part J4, TAS Part J & Housing Provisions – NSW 13.2.5, NT 13.2.5, TAS 13.2</p> <p>The wall system contributes towards the Total wall system U or R value, which is to be determined in accordance with Volume 1 – J4D6 & Housing Provisions – 13.2.5 or specific state variation.</p> <p>Insulation shall be included within the wall system, as outlined in the relevant Design & Installation Manual & according to project specifications.</p>	<p>1, 2, 3, 4, 5, 6, 7, 8, 9 & 10</p>
<p>General</p> <p>The supporting structures including stud frame & cavity sub framing, plus internal linings shall be designed & specified by a suitably qualified design professional in accordance with manufacturer guidelines and installed by suitably qualified and trained building professionals, in accordance with manufacturer guidelines and the relevant ONE AAC Design and Installation Manuals, refer Appendix B2.</p>	<p>1, 2, 3, 4, 5, 6, 7, 8, 9 & 10</p>



Certificate of Conformity

APPENDIX A – PRODUCT TECHNICAL DATA

A1 Type and intended use of product

Refer to page 1 of this certificate.

A2 Description of product

Refer to page 1 of this certificate.

A3 Product specification

Refer to items 1, 2, 3, 4 & 5 listed in Appendix B2:

- ONE AAC PANEL External Wall System Design and Installation Manual, dated September 2019.
- ONE AAC PANEL Floor System Design and Installation Manual, dated September 2019.
- ONE AAC PANEL Party Wall System Design and Installation Manual, dated September 2019.
- ONE AAC PANEL Dual Boundary Wall System Design and Installation Manual, dated September 2019.
- ONE AAC PANEL Dual Boundary Wall Presentation (DWG & Photos), dated September 2019.

A4 Manufacturer and manufacturing plant(s)

ONE AAC PANEL

485 Campbelltown Rd
Denham Court NSW 2565
Ph: 1300 010 222
www.oneaac.com.au

A5 Installation requirements

Refer to items 1, 2, 3, 4 & 5 listed in Appendix B2:

- ONE AAC PANEL External Wall System Design and Installation Manual, dated September 2019.
- ONE AAC PANEL Floor System Design and Installation Manual, dated September 2019.
- ONE AAC PANEL Party Wall System Design and Installation Manual, dated September 2019.
- ONE AAC PANEL Dual Boundary Wall System Design and Installation Manual, dated September 2019.
- ONE AAC PANEL Dual Boundary Wall Presentation (DWG & Photos), dated September 2019.

A6 Other relevant technical data

Refer to items 1, 2, 3, 4 & 5 listed in Appendix B2:

- ONE AAC PANEL External Wall System Design and Installation Manual, dated September 2019.
- ONE AAC PANEL Floor System Design and Installation Manual, dated September 2019.
- ONE AAC PANEL Party Wall System Design and Installation Manual, dated September 2019.
- ONE AAC PANEL Dual Boundary Wall System Design and Installation Manual, dated September 2019.
- ONE AAC PANEL Dual Boundary Wall Presentation (DWG & Photos), dated September 2019.

And any referenced documents within the technical literature identified in Appendices A3 & A5.

Certificate number: CM30031

This certificate is only valid when reproduced in its entirety.

Page 7 of 10

APPENDIX B – EVALUATION STATEMENTS

B1 Evaluation methods

The following assessment methods have been used to determine compliance with BCA 2022:

Code Clause	Assessment Method(s)	Evidence of suitability	Evidence reference in B2
BCA Volume One B1P1	A2G2 (2) (a) & (c)	A5G3 (1) (e) & (f) – Expert judgement & Other documentary evidence	Items 1, 2, 3, 4, 5, 6, 7, 8, 9, 10, 11, 12, 13, 14, 15, 16, 17, 18, 19 & 20
BCA Volume Two H1P1	A2G2 (2) (a) & (c)	A5G3 (1) (e) & (f) – Expert judgement & Other documentary evidence	Items 1, 2, 3, 4, 5, 6, 7, 8, 9, 10, 11, 12, 13, 14, 15, 16, 17, 18, 19 & 20
BCA Volume One B1P2	A2G2 (2) (a) & (c)	A5G3 (1) (e) & (f) – Expert judgement & Other documentary evidence	Items 1, 2, 3, 4, 5, 6, 7, 8, 9, 10, 11, 12, 13, 14, 15, 16, 17, 18, 19 & 20
BCA Volume One B1D4 (b)(ii)	A2G3 (2) (a) & (b)	A5G3 (1) (e) & (f) – Expert judgement & Other documentary evidence	Items 1, 2, 3, 4, 5, 6, 7, 34, 35
BCA Volume Two H1D7 (4)(a)	A2G3 (2) (a) & (b)	A5G3 (1) (e) & (f) – Expert judgement & Other documentary evidence	Items 1, 2, 3, 4, 5, 6, 7, 34, 35
BCA Volume One C2D10	A2G3 (2) (a)	A5.2 (1) (d) – Test report	Items 26 & 33
BCA Volume One C2D2	A2G3 (2) (a) & (b)	A5G3 (1) (d) & (e) – Test report & Expert judgement	Items 21, 22, 23, 24, 25, 26, 27, 28, 29, 30, 31, 32 & 33
BCA Volume One Specification 1	A2G3 (2) (a) & (b)	A5G3 (1) (d) & (e) – Test report & Expert judgement	Items 21, 22, 23, 24, 25, 26, 27, 28, 29, 30, 31, 32 & 33
BCA Volume One Specification 5	A2G3 (2) (a) & (b)	A5G3 (1) (d) & (e) – Test report & Expert judgement	Items 21, 22, 23, 24, 25, 26, 27, 28, 29, 30, 31, 32 & 33
BCA Volume Two H3D3	A2G3 (2) (a) & (b)	A5G3 (1) (d) & (e) – Test report & Expert judgement	Items 21, 22, 23, 24, 25, 26, 27, 28, 29, 30, 31, 32 & 33
BCA Volume Two Specification 1	A2G3 (2) (a) & (b)	A5G3 (1) (d) & (e) – Test report & Expert judgement	Items 21, 22, 23, 24, 25, 26, 27, 28, 29, 30, 31, 32 & 33
Housing Provisions 9.2.3	A2G3 (2) (a) & (b)	A5G3 (1) (d) & (e) – Test report & Expert judgement	Items 21, 22, 23, 24, 25, 26, 27, 28, 29, 30, 31, 32 & 33
Housing Provisions 9.3.1	A2G3 (2) (a) & (b)	A5G3 (1) (d) & (e) – Test report & Expert judgement	Items 21, 22, 23, 24, 25, 26, 27, 28, 29, 30, 31, 32 & 33
Housing Provisions 9.3.4	A2G3 (2) (a) & (b)	A5G3 (1) (d) & (e) – Test report & Expert judgement	Items 21, 22, 23, 24, 25, 26, 27, 28, 29, 30, 31, 32 & 33
Housing Provisions 9.4.1	A2G3 (2) (a) & (b)	A5G3 (1) (d) & (e) – Test report & Expert judgement	Items 21, 22, 23, 24, 25, 26, 27, 28, 29, 30, 31, 32 & 33
BCA Volume One F1D6	A2G3 (2) (a) & (b)	A5G3 (1) (e) & (f) – Expert judgement & Other documentary evidence	Items 1, 34, 35
BCA Volume One F3D5 (1)(b)	A2G3 (2) (a) & (b)	A5G3 (1) (e) – Expert judgement	Items 34, 35
BCA Volume Two H2D6 (4)	A2G3 (2) (a) & (b)	A5G3 (1) (e) – Expert judgement	Items 34, 35
BCA Volume One F7D3	A2G3 (2) (a) & (b)	A5G3 (1) (d) & (e) – Test report & Expert judgement	Items 36, 37, 38, 39, 40, 41, 42 & 43
BCA Volume One F7D4	A2G3 (2) (a) & (b)	A5G3 (1) (d) & (e) – Test report & Expert judgement	Items 36, 37, 38, 39, 40, 41, 42 & 43
BCA Volume One F7D5	A2G3 (2) (a) & (b)	A5G3 (1) (d) & (e) – Test report & Expert judgement	Items 36, 37, 38, 39, 40, 41, 42 & 43
BCA Volume One F7D6	A2G3 (2) (a) & (b)	A5G3 (1) (d) & (e) – Test report & Expert judgement	Items 36, 37, 38, 39, 40, 41, 42 & 43
Housing Provisions 10.7.1	A2G3 (2) (a) & (b)	A5G3 (1) (d) & (e) – Test report & Expert judgement	Items 36, 37, 38, 39, 40, 41, 42 & 43
Housing Provisions 10.7.2	A2G3 (2) (a) & (b)	A5G3 (1) (d) & (e) – Test report & Expert judgement	Items 36, 37, 38, 39, 40, 41, 42 & 43
Housing Provisions 10.7.3	A2G3 (2) (a) & (b)	A5G3 (1) (d) & (e) – Test report & Expert judgement	Items 36, 37, 38, 39, 40, 41, 42 & 43
BCA Volume One G5D3	A2G3 (2) (a) & (b)	A5G3 (1) (d) & (e) – Test report & Expert judgement	Items 21, 22, 23, 24, 26, 27, 29, 30, 32 & 33
BCA Volume One G5D4	A2G3 (2) (a) & (b)	A5G3 (1) (d) & (e) – Test report & Expert judgement	Items 21, 22, 23, 24, 26, 27, 29, 30, 32 & 33
BCA Volume Two H7D4(2)(a)	A2G3 (2) (a) & (b)	A5G3 (1) (d) & (e) – Test report & Expert judgement	Items 21, 22, 23, 24, 26, 27, 29, 30, 32 & 33
BCA Volume One J4D6	A2G3 (2) (a) & (b)	A5G3 (1) (e) – Expert judgement	Items 44, 45, 46, 47, 48 & 49
Housing Provisions 13.2.5	A2G3 (2) (a) & (b)	A5G3 (1) (e) – Expert judgement	Items 44, 45, 46, 47, 48 & 49
BCA Volume One NT B1D4(b)(i)	A2G3 (2) (a) & (b)	A5G3 (1) (e) & (f) – Expert judgement & Other documentary evidence	Items 1, 2, 3, 4, 5, 6, 7, 34, 35
BCA Volume One QLD B1D4(b)(ii)	A2G3 (2) (a) & (b)	A5G3 (1) (e) & (f) – Expert judgement & Other documentary evidence	Items 1, 2, 3, 4, 5, 6, 7, 34, 35

BCA Volume One	WA B1D4(b)(ii)	A2G3 (2) (a) & (b)	A5G3 (1) (e) & (f) – Expert judgement & Other documentary evidence	Items 1, 2, 3, 4, 5, 6, 7, 34, 35
BCA Volume Two	WA H1D7(4)(a)	A2G3 (2) (a) & (b)	A5G3 (1) (e) & (f) – Expert judgement & Other documentary evidence	Items 1, 2, 3, 4, 5, 6, 7, 34, 35
Housing Provisions	NSW 9.4.1	A2G3 (2) (a) & (b)	A5G3 (1) (d) & (e) – Test report & Expert judgement	Items 21, 22, 23, 24, 25, 26, 27, 28, 29, 30, 31, 32 & 33
Housing Provisions	NSW 9.4.3	A2G3 (2) (a) & (b)	A5G3 (1) (d) & (e) – Test report & Expert judgement	Items 21, 22, 23, 24, 25, 26, 27, 28, 29, 30, 31, 32 & 33
BCA Volume One	SA F1D6(2)	A2G3 (2) (a) & (b)	A5G3 (1) (e) & (f) – Expert judgement & Other documentary evidence	Items 1, 34, 35
BCA Volume One	NT F7	A2G3 (2) (a) & (b)	A5G3 (1) (d) & (e) – Test report & Expert judgement	Items 36, 37, 38, 39, 40, 41, 42 & 43
Housing Provisions	NT 10.7	A2G3 (2) (a) & (b)	A5G3 (1) (d) & (e) – Test report & Expert judgement	Items 36, 37, 38, 39, 40, 41, 42 & 43
BCA Volume One	NSW G5D3	A2G3 (2) (a) & (b)	A5G3 (1) (d) & (e) – Test report & Expert judgement	Items 21, 22, 23, 24, 26, 27, 29, 30, 32 & 33
BCA Volume Two	NSW H7D4(2)(a)	A2G3 (2) (a) & (b)	A5G3 (1) (d) & (e) – Test report & Expert judgement	Items 21, 22, 23, 24, 26, 27, 29, 30, 32 & 33
BCA Volume One	NSW G5D4	A2G3 (2) (a) & (b)	A5G3 (1) (d) & (e) – Test report & Expert judgement	Items 21, 22, 23, 24, 26, 27, 29, 30, 32 & 33
BCA Volume One	VIC G5D4	A2G3 (2) (a) & (b)	A5G3 (1) (d) & (e) – Test report & Expert judgement	Items 21, 22, 23, 24, 26, 27, 29, 30, 32 & 33
BCA Volume One	NSW J4D6	A2G3 (2) (a) & (b)	A5G3 (1) (e) – Expert judgement	Items 44, 45, 46, 47, 48 & 49
BCA Volume One	NSW Section J	A2G3 (2) (a) & (b)	A5G3 (1) (e) – Expert judgement	Items 44, 45, 46, 47, 48 & 49
BCA Volume One	NT Part J4	A2G3 (2) (a) & (b)	A5G3 (1) (e) – Expert judgement	Items 44, 45, 46, 47, 48 & 49
BCA Volume One	TAS Section J	A2G3 (2) (a) & (b)	A5G3 (1) (e) – Expert judgement	Items 44, 45, 46, 47, 48 & 49
BCA Volume Two	NSW Part H6	A2G3 (2) (a) & (b)	A5G3 (1) (e) – Expert judgement	Items 44, 45, 46, 47, 48 & 49
Housing Provisions	NSW 13.2.5	A2G3 (2) (a) & (b)	A5G3 (1) (e) – Expert judgement	Items 44, 45, 46, 47, 48 & 49
BCA Volume Two	NT Part H6	A2G3 (2) (a) & (b)	A5G3 (1) (e) – Expert judgement	Items 44, 45, 46, 47, 48 & 49
Housing Provisions	NT 13.2.5	A2G3 (2) (a) & (b)	A5G3 (1) (e) – Expert judgement	Items 44, 45, 46, 47, 48 & 49
BCA Volume Two	TAS Part H6	A2G3 (2) (a) & (b)	A5G3 (1) (e) – Expert judgement	Items 44, 45, 46, 47, 48 & 49
Housing Provisions	TAS 13.2	A2G3 (2) (a) & (b)	A5G3 (1) (e) – Expert judgement	Items 44, 45, 46, 47, 48 & 49

B2 Reports

The following reports have been used as evidence to determine compliance with BCA 2022

Ref	Author	Reference	Date	Description	NATA Registration
1	ONE AAC PANEL	External Wall Design & Installation Manual	March 2022	Client published design & installation manual	-
2	ONE AAC PANEL	Flooring Design & Installation Manual	March 2022	Client published design & installation manual	-
3	ONE AAC PANEL	Party Wall Design & Installation Manual	March 2022	Client published design & installation manual	-
4	ONE AAC PANEL	Dual Zero Boundary Wall Design & Installation Manual	March 2022	Client published design & installation manual	-
5	ONE AAC PANEL	Dual Zero Boundary Wall Construction Details	March 2022	Client published drawings and details	-
6*	Enertrren	ONE-007 V.4	10 Feb 2022	Compliance review of ONE AAC systems against NCC	-
7*	Enertrren	ONE-013 V.3	10 Feb 2022	Compliance review of ONE AAC systems against NCC	-
8*	ONE AAC PANEL	Batch Testing 50mm Panel	15 Mar 2018	Quality control structural test document	-
9*	Enertrren	AS4055-2006 Connection Design	13 Apr 2009	Structural calculation report	-
10*	Enertrren	ONE-011 V.1	10 Feb 2022	Structural Design Certification	-
11*	Enertrren	ONE-012 V.3	10 Feb 2022	Structural Design Certification	-
12*	BEMAC Laboratories	10953	6 Mar 2017	Structural test report	1393
13*	BEMAC Laboratories	10953	4 May 2017	Structural test report	1393
14*	Pace Structural	PS 18109	27 Feb 2020	Structural Design Certification	-

15*	Pace Structural	PS 18013	13 May 2020	Structural Design Certification	-
16*	Pace Structural	PS 18022	13 May 2020	Structural Design Certification	-
17*	Pace Structural	PS 20116	25 Aug 2020	Structural Design Certification	-
18*	Pace Structural	PS 20123	28 Aug 2020	Structural Design Certification	-
19*	Mahaffey Associates	BAS/13/L02/9830	30 Jul 2013	Durability assessment report	-
20*	The Coatings Consultancy	TCC18025-B-20200612	12 Jun 2020	Durability assessment report	-
21*	CSIRO	FSV 1525	15 Feb 2012	Fire test report	165
22*	CSIRO	COT 2363	15 Feb 2012	Fire test certificate	165
23*	CSIRO	FCO 2915	30 Mar 2012	Fire assessment report	165
24*	CSIRO	FCO 2944	29 Aug 2012	Fire assessment report	165
25*	CSIRO	FCO 3023	20 Sep 2013	Fire assessment report	165
26*	CSIRO	FNC-11128	9 May 2014	Fire test report	165
27*	CSIRO	FCO 3111	20 Apr 2014	Fire assessment report	165
28*	WarringtonFire	FAS190191 RIR1.1	25 May 2020	Regulatory information report – Fire	3277
29*	EXOVA WarringtonFire	24917-02	11 Mar 2013	Fire assessment report	3277
30*	WarringtonFire	FAS200114 R1.0	24 Apr 2020	Fire assessment report	3277
31*	CSIRO	FCO-3255 Rev D	17 Oct 2017	Fire assessment report	165
32*	CSIRO	FCO-2532 Rev F	12 Aug 2021	Fire assessment report	165
33*	CSIRO	FNC12427A	2 Sep 2019	Fire test certificate	165
34*	Energren	ONE-009 V.1	5 Sep 2019	Weatherproofing assessment report	-
35*	AECOM	2021.04.08_FV1.1_HEB	8 Apr 2021	Weatherproofing assessment report	-
36*	Renzo Tonin & Assoc	TG553-01F02	6 Feb 2014	Acoustic assessment report	-
37*	Koikas Acoustics	2679C20150827	3 Jun 2015	Acoustic assessment report	-
38*	Koikas Acoustics	2878C20151112	12 Nov 2015	Acoustic assessment report	-
39*	Koikas Acoustics	2878C20181031	9 Nov 2016	Acoustic assessment report	-
40*	AcousticLogic	201307861.1/0209A/R0/GW	2 Sep 2013	Acoustic assessment report	-
41*	AcousticLogic	20140366.35/0202A/R6/GW	2 Feb 2018	Acoustic assessment report	-
42*	AcousticLogic	20171728.13/0507A/R6/GW	1 May 2019	Acoustic assessment report	-
43*	AcousticLogic	20171728.18/1302A/R1/GW	13 Feb 2020	Acoustic assessment report	-
44*	Energren	75mm Panel R-Value	27 Nov 2015	Thermal assessment report	-
45*	Energren	ONE-AAC Cladding Wall 75mm R Values	9 Apr 2013	Thermal assessment report	-
46*	James M Fricker	i107e	1 Oct 2020	Thermal assessment report	-
47*	James M Fricker	107.23i – 107.29i	1 Sep 2020	Thermal assessment report (timber frame)	-
48*	James M Fricker	107.23i – 107.29i	1 Sep 2020	Thermal assessment report (steel frame)	-
49*	CSR Insulation	NR-12140	10 Oct 2012	Thermal test report	993

* The Certificate Holder has chosen not to make the above identified evidence of compliance publicly available, due to the documents being considered commercial in confidence.

Notes:

ONE AAC PANEL

Head Office:

485 Campbelltown Rd

Denham Court NSW 2565

Tel: **1300 010 222 (AAC) or 02 9756 5029**

Mobile: 0439 28 30 30

Email: info@oneaac.com.au

Web: www.oneaac.com.au