



ONE AAC

PANEL

AAC FIRE & ACOUSTIC SOLUTIONS

50mm & 75mm AAC PANEL PARTY WALL SYSTEMS

DESIGN & INSTALLATION MANUAL

September 2019 Edition



Preface

The ONE AAC PANEL Party Wall System Design & Installation Manual has been developed to provide design, installation and technical information to 'end users' ranging from the owner builder, licensed builders, building consultants, designers, architects and engineers.

Although the details provided in this Design & Installation Manual have been developed by ONE AAC and are intended to represent good building practice, the registered professionals involved in the project (such as the licensed builder, architectural designer and engineering consultant) must ensure that the information provided in this Design & Installation Manual is appropriate and suitable for the project.

Contents

Introduction To ONE AAC	3-4
❖ What is AAC	
❖ Manufacturing Process	
BCA Compliance	5
❖ Compliance with the Building Code of Australia	
System Overview & Performance	6-7
❖ Material Properties	
❖ Fire Resistance	
❖ Acoustic Performance	
❖ Design Principles	
System Components	8-9
❖ Panel	
❖ Panel Adhesive	
❖ C-Section Base Track (Optional)	
❖ H-Section Joiner Stud	
❖ Slotted Angle	
❖ Metal Battens	
❖ Aluminum Brackets	
❖ Fasteners	
❖ Fire Rated Sealant	
System Selection & Installation Process	10-13
❖ System Installation Sequence	
❖ Installation Summary	
❖ Tools & Equipment	
Delivery Storage & Handling	14
❖ Delivery	
❖ Storage and Handling	
Occupational Health and Safety	14
Warranty & Guarantee	15
Drawings & Details	16-21
CodeMark Certificate Of Conformity	22

Introduction

ONE AAC is known as a market leader in Aerated Autoclaved Concrete (AAC) Panel Solutions for residential and commercial construction.

ONE AAC combines 25 years of construction experience, product and systems development knowledge and material distribution expertise, to ensure its customers receive the best construction solutions for their projects, at the best possible price, with the fastest possible turnaround.

ONE AAC supplies to the construction industry and specialises in **Fire** and **Acoustic** Solutions for **wall** and **floor** systems, in both **commercial** and **residential** applications.

Solutions include, but are not limited to:

- **Internal Wall Systems (Intertenancy / Party Walls) – Low Rise and High Rise**
- External Rendered Wall Systems – Low Rise and High Rise Façades
- Boundary Walls - Single and Dual Wall Options
- Floor and Ceiling Systems
- Fence Systems - Boundary and Estate Fencing Solutions

**Solutions Can Be Resolved in 50mm or 75mm Thick
ONE AAC PANEL - The Choice is Yours.**

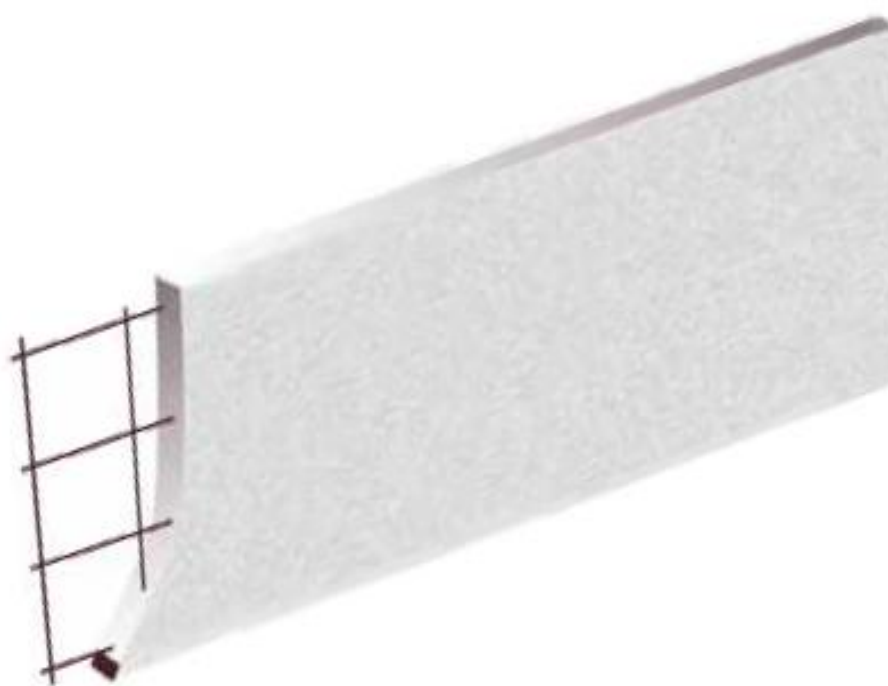

STEEL REINFORCED - 50MM AND 75MM ONE AAC PANEL

What Is AAC? (Lightweight Concrete)

Autoclaved Aerated Concrete (AAC) is manufactured from cement, sand (silica), lime and water, it is aerated by adding an expanding agent to the mix (small amounts of aluminium paste). The mix is poured into a mould (a very large cake tin), to approximately 2/3 of the height of the mould, almost instantly the expanding agent reacts with the other elements, and the mix begins to rise in the mould. (A chemical reaction expands the mixture to form small, finely-dispersed air bubbles).

The moulds are pre-cured in a heated room for several hours. Then the semi -solid material (still in a green state) is transported to the cutting machine. The soft but semi-solid block is sliced into the required panel size using steel wires. Once sliced, the block is steam pressure cured in autoclaves for up to 12 hours. The expanding chemical reaction combined with the Autoclave process is what gives AAC it's unique properties. AAC has excellent thermal insulation and acoustic absorption properties, it has superior fire resistance qualities and is also termite resistant.

Its properties and specification satisfy all relevant building codes. Working with AAC is easy and efficient. AAC is both versatile and economical. AAC meets the diverse demands better than any other material due to the numerous advantages of its physical and mechanical properties.

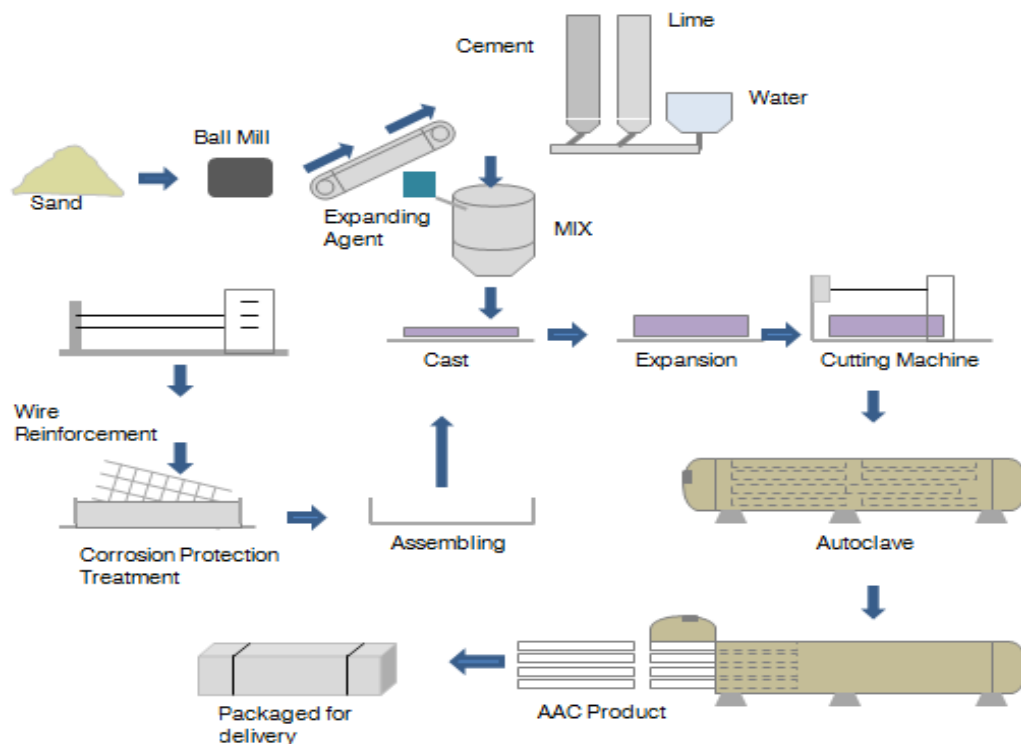

THE ONE AAC PANEL MANUFACTURING PROCESS

The ONE AAC Panel System - BCA Compliance

The BCA is part of the Australian National Construction Code system and defines minimum standards for buildings. The BCA consists of two volumes:

Volume One - provides requirements for commercial, residential and public building defined as Class 2 to 9 in the BCA. Typical examples include offices, commercial, health buildings, flats and boarding houses.

Volume Two – Housing Provisions, considers domestic construction defined as Class 1 and 10. Typical examples include houses, garages, swimming pools, carports and the like. The BCA is a performance based building code and contains requirements for Structures, Fire Resistance; Damp & Weatherproofing, Sound Transmissions & Insulation and Energy Efficiency.

The ONE AAC Panel System has been assessed to meet and comply with all the necessary performance requirements of the BCA. This design & Installation Manual contains the information necessary to assist in the design of a project.

The designer should ensure the proposed use of the system satisfies the Performance Requirements and provides sufficient design information (including ONE AAC appraisal and installation manuals) to satisfy the requirements of the appropriate authority.

ONE AAC Panel has achieved the CODEMARK CERTIFICATE OF COMFORMITY issued by Global-Mark in Australia (Certificate Number GM_CM30031 Rev 1) to meet all the required provisions of the Building Code of Australia **for Volume One and Volume Two** and has been appraised as an **Alternative Solution** in terms of compliance with the Building Code of Australia as listed below:



1. **Volume One BP1.1, BP1.2, B1.4 and Volume Two P2.1.1, 3.5.4.0** in respect of structural performance;
2. **Volume One A5.4, C1.1, C1.9 and Volume Two 3.7.2.4, 3.7.3.2/5 and 3.7.4.3** in respect of fire performance;
3. **Volume One FP1.4, F1.9 and Volume Two P2.2.2** in respect of damp weatherproofing;
4. **Volume One F5.2/3/4/5 and Volume Two 3.8.6.2/3/4** in respect of acoustic performance;
6. **Volume One G5.2 and Volume Two 3.10.5.0(c)** in respect of Construction in Bushfire Prone Areas;
7. **Volume One J1.5 and Volume Two 3.12.1.4** in respect of Building Fabric Thermal Insulation;

The Code Mark Certificate is attached in the Appendix of this Design and Installation Manual or visit www.oneaac.com.au to download a copy.

Standard Compliance

All works shall be carried out in accordance with the Building Code of Australia (BCA) and where necessary nominated reference standards.

AS 1720 Timber Framing Code and AS 1684-2006 National Timber Framing Code

AS 2870-1996 Residential Slabs and Footing Construction and AS 3600-2001 Concrete Structures

AS 3959-2009 Construction of Buildings in Bushfire-Prone Zone Areas

AS 2904-1995 Damp-proof course and flashings

AS 1170 Part 1 Loading Code and AS 1170 Part 2 Wind Code

AS 3660.1-2001 Protection of Buildings against subterranean Termite – Part 1 New Buildings

AS 4055-2006 Wind Loading for Housing

AS 3623 and AS/NZ 4600 – Steel Framing and NASH Standard 2005, Part 1 – Steel Framing

Where standards have been revised, the most current version shall apply

For a copy of the relevant compliance documents visit our website: www.oneaac.com.au

Material Properties

Property	50MM PANELS		75MM PANELS	
	Value	Units	Value	Units
Ambient ¹ Density, ρ_{amb}	520	kg/m ³	520	kg/m ³
Dry ² Density, ρ_{dry}	500	kg/m ³	500	kg/m ³
Working ³ Density, ρ_{design}	610	kg/m ³	622	kg/m ³
Permanent Action, G	0.3	kN/m ²	0.5	kN/m ²
Characteristic Unconfined Compressive Strength, f_{uc}	1.1	MPa	1.1	MPa
Modulus of Rupture, f_{ut}	0.73	MPa	0.73	MPa
Design Ultimate Limit State Bending Capacity, ϕM	0.12	kNm	0.25	kNm
Design Serviceability Limit State Deflection Limit, δ_{max}	$SPAN/240$		$SPAN/240$	
Coefficient of contraction	0.4	mm/m	0.4	mm/m
Coefficient of thermal expansion	10	$\times 10^{-6}/^{\circ}C$	10	$\times 10^{-6}/^{\circ}C$

Notes:

1. Ambient density is that achieved by the product when it has reached equilibrium at 23°C, 50% RH. The moisture content by mass in this state is typically between 2% and 5%.
2. Dry density is the manufacturer's reported density, the typical frame of reference for grading AAC material. It is achieved by oven drying specimens so that the moisture content is 0%.
3. Working density is to be used for calculation of effects due to permanent actions.
4. Moment capacity quoted is for 600mm wide panels.

Quality from start to finish

ONE AAC and associated manufacturers both adhere to the ISO 9001 international standards for management of quality. With these measures in place plus strict system protocol ONE AAC offers a warranty of 15 years on materials adding peace of mind to your project.

Fire Resistance

AAC materials have exceptional fire resistance and are non-combustible. In the event of fire ONE AAC Panels will not emit any toxic gases or vapours. The ONE AAC Panel System meets the performance requirements of P2.3.1 of the BCA for use as a Party Wall, providing FRL's options of 60/60/60 or 90/90/90 or 120/120/120 – (all options are supported via CSIRO Reports and Assessments).



Photo courtesy of www.budwell.com

Acoustic Performance

The ONE AAC Party Wall Systems offers good acoustic performance. The acoustic performances, meet and exceed the minimum BCA requirements. To further increase the acoustic performance, the use of sound insulation materials and sound rated plasterboard is recommended.

- The Bare 50mm ONE AAC Panel has an $R_w = 33$
- The Bare 75mm ONE AAC Panel has an $R_w = 35$
- The ONE AAC PANEL Party Wall Systems achieve the minimum $R_w + C_{tr} = 50$
- They comply with the requirements for Discontinuous Construction

Design Principles for the ONE AAC Panel System

The design principles which the ONE AAC Panel System are based on, are those used in both residential framed construction as well as residential concrete frame with light weight frame infill construction.

Multi Storey Construction

ONE AAC Panels can be used for both Low Rise and High Rise Multi-Residential construction when fixed in accordance with the ONE AAC Panel Systems

Framing Design for the ONE AAC PANEL System

In either, Load Bearing (typically low rise framed construction) or Non - Load Bearing (typically high-rise slab to slab construction) residential projects, the support structure including the stud frame, shall be designed by the frame manufacturer or the relevant design engineer, and should be designed in accordance with the specific codes for concrete, timber or steel frame construction types.



ONE AAC



PARTYWALLS

ONE AAC Panel System Components

ONE AAC PANELS

The ONE AAC Panels are steel reinforced and are manufactured from autoclaved aerated concrete with a dry density of 520kg/m³-560kg/m³. The 50mm and 75mm thick ONE AAC Panels are supplied in a standard length of 2200mm and a standard width of 600mm, and have an average mass of approx. **40kg/panel for the 50mm thick panels** and approx. **62kg/panel for the 75mm thick panels**. Other lengths are available for the 75mm panels ranging from 2200mm to 3600mm

ONE AAC PANEL Adhesive

The ONE AAC Panel Adhesive is a polymer modified cement-based adhesive supplied in 20kg bags. It is supplied by ONE AAC, mixed on-site with clean water (see instructions printed ONE AAC bag), and is applied to all edges of the panels (except control joint). ONE AAC Panel Adhesive is also used for bonding Decorative Trims and banding, along with minor patching, repairs and stopping of screw heads on the ONE AAC panels.

Base Channel / C-Section Channel

The 51mm x 28mm x 0.5 BMT C-Section when used as a base or end channel abutting masonry, is to be fixed using M6 masonry anchors at a max of 1800mm centres. When used as end channels of load bearing framed party walls, they must be fixed via aluminium brackets to the periphery (end studs) at a maximum of 1500mm centres. For slab to slab (non-load bearing) construction, the end C-Section Channel is located within the base channel at the base and fixed at the top to a slotted angle.

H-Section Joiner Stud (60 Minute Systems)

The 51mm x 0.5 BMT H-Section Joiner Stud are located at a maximum of 2200mm centres and are fixed to each intersecting bottom plate, top plate, bottom chord and rafter of each frame either side of the AAC Wall. For slab to slab (non-load bearing) construction, the H-Section Joiner Stud is located within the base channel at the base and fixed at the top to a slotted angle.



Slotted Angle / Top Angle

The 75mm x 50mm x 1.15BMT slotted angle is used for the slab to slab (Non-Load Bearing) is fixed to the concrete ceiling at 600mm centres using masonry anchors or shot fired nails to withstand a minimum shear load of 0.80kN/m (based on a 4.2m high wall at 0.375 kPa ultimate wind pressure)

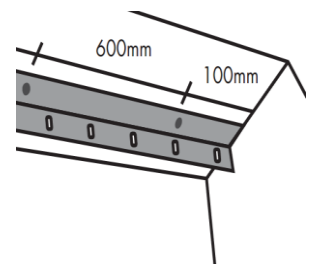

16mm Metal Batten (90 Minute Systems)

The 16mm x 0.5 BMT Metal Battens are located (one side of AAC Wall only) at a maximum of 1100mm centres and are fixed to each intersecting bottom plate, top plate, bottom chord and rafter. For slab to slab (non-load bearing) construction, the 16mm Metal Batten is fixed to the outside of the base channel at the base and fixed at the top to a slotted angle.

Aluminium Brackets

The 70 x 40 x 1.5 x 50mm wide Aluminium Brackets are used to connect the timber or steel frame either side of the AAC panel wall. The Aluminium Brackets are fixed at a maximum of 1100mm centres at each intersecting bottom plate (without a base channel), top plate, bottom chord and rafter of each frame either side of the AAC panel wall.



Timber Frame Screws

12-11 x 25mm Hex Head Type 17 screws are used to fix the aluminium brackets to the timber frame. Two screws per bracket are required.



Steel Frame Screws

10-16 x 16mm Hex Head Self Drilling Screws are used to fix the aluminium brackets to the Metal C-Section Channel or the Aluminium Brackets to the Metal H-Section Joiner Studs. Two screws per bracket are required.



Panel Screws

14-10 x 45mm Hex Head Type 17 screws are used to fix the aluminium brackets to the AAC Panel at mid span. Two screws per bracket are required. As fixings into the AAC are prone to being over tightened and stripping, it is good practice to drive each of the two screws in opposite directions (a slight direction away from each other)



Fire Rated Sealant

An approved fire rated sealant such as SWIRL Engineering, Knauf Bindex, Fullers FIRESOUND Fire Rated Acoustic Sealant or Bostik FIREBAN ONE Low Modulus Fire Rated Polyurethane Sealant or equivalent must be used in control joints in all fire rated wall applications such as boundary walls.

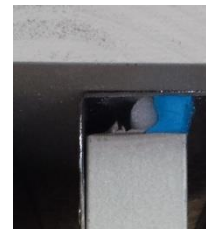

System Selection & Installation Process

System Selection

SYSTEM	PANEL THICKNESS (mm)	CONSTRUCTION TYPE	FRL	Rw+Ctr
1 – 60 LB Stack Bond, H-Stud	50mm:	Framed: Timber or Steel Frame	60/60/60	53
1S – 60 NLB Stack Bond, H-Stud	50mm:	Slab to Slab: Timber or Steel frame infill	-/60/60	53
2 – 90 LB Stretcher Bond, batten 1 side	50mm	Framed: Timber or Steel Frame	90/90/90	53
2S – 90 NLB Stretcher Bond, batten 1 side	50mm	Slab to Slab: Timber or Steel frame infill	-/90/90	53
3 – 120 LB Vertical Panel	75mm	Framed: Timber or Steel Frame	120/120/120	55
3S – 120 NLB Vertical Panel	75mm	Slab to Slab: Timber or Steel frame infill	-/120/120	55

Benefits

- Systems comply with the minimum requirements of the BCA for Fire and Acoustics for Discontinuous Construction
- Simple and easy to install, which can be installed by existing trades for continuity of work.
- Does not require the use of fire rated plasterboard to achieve the fire rating.
- Weather resistant during construction, the AAC panels will not bend, soften, grow mold or deteriorate in wet weather
- Fast and achieves significant cost savings over traditional masonry systems



ONE AAC

PARTYWALLS

ONE AAC Panel System Installation Sequence – 50mm Panel Systems

- **Fix C-Section to end of wall:** Via Aluminium Brackets for framed constructions or to base channel and slotted angle for slab to slab construction



- **Choose Base Detail:** Adhesive or Base Channel Option



- **For System 2 and 2S (90 minute systems):** fix first metal batten at 1100mm centers starting with the first metal batten at 550mm from end of wall.

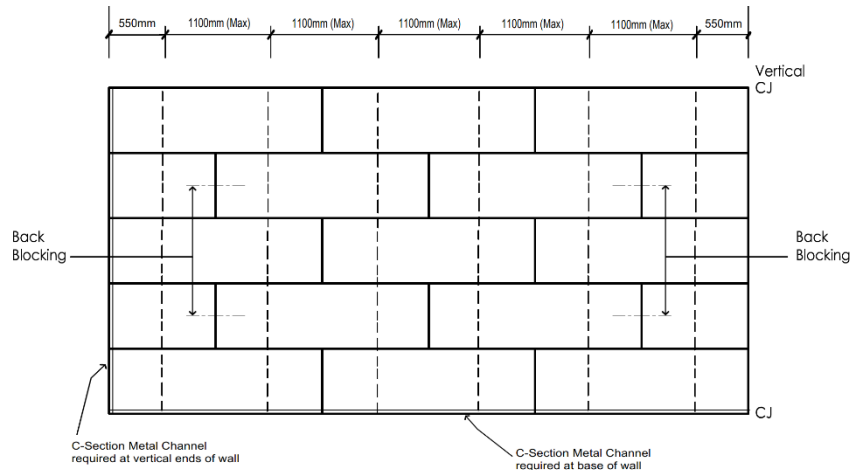

- **Mix Panel Adhesive**

- **Install Panel:** For **Stack Bond** installation, panels are laid one panel on the other in a stack bond pattern and are located within the H-Section Joiner Studs. For **Stretcher Bond** installation, the panels are fixed to the metal battens (2 screws per intersecting batten), either rear fixed using 45mm or 65mm hex head screws or face fixed using 75mm bugle head screws. The face fixed screws are to be embedded a minimum of 5mm and patched over using the ONE AAC adhesive.

- **Apply Adhesive:** ONE AAC PANEL Adhesive is only required to the horizontal joints for the stack bond system (the adhesive is not required at the H-Section Joiner Stud), however it is required to both the horizontal and vertical panel joints for the stretcher bond system.
- **Aluminium Bracket Installation:** Ensure Aluminium Brackets are fixed at a maximum of 1100mm centers at each intersecting bottom plate (without a base channel), top plate, bottom chord and rafter of each frame either side of the AAC panel wall. An equal number of brackets are required to each side of the AAC Panel wall.



- **Continue Panel Installation** to the perimeter intersections such as the external walls, roof line, slab ceiling etc.
- **Perimeter Intersections** are to be treated to prevent fire, sound and smoke passing through the AAC panel wall. Intersecting T-Junctions may be Cavity Type or Non-Cavity Type intersections.
 - **Cavity Type Intersections** are to be packed tightly with Fire Resistant Mineral Wool, all intersections with external walls will also require damp proof course between the external wall and the mineral wool to prevent moisture wetting the mineral wool and causing it to become displaced.
 - **Non-Cavity Type Intersections** are to be sealed with a bead of Fire Rated Sealant beneath and to at least one vertical side of the metal C-Section Channel which is fixed to the intersecting T-Junction. Ensure panels are completely inserted into the C-Section Channels.

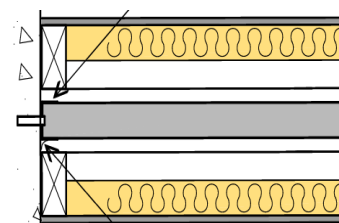
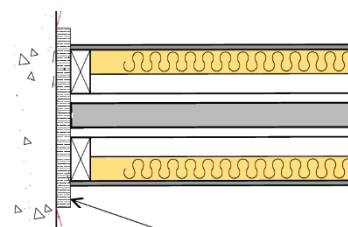

- **Eaves Detail and Temporary Bracing:** Panels can be canter-levered to close the eaves void, and walls should not be left unbraced as they may be prone to be blown over if left unbraced.



Basic Tools Required When Working With AAC

The basic tools required when working with AAC are typically used by the carpentry and rendering trades and are readily available and relatively inexpensive when it comes to the complete set up for working with AAC.

Some of the tools required to make the job easy are identified below:

- ◆ Personal Protective Equipment
 - High Visibility Work Wear, Steel Cap Boots
 - Gloves, Dust Mask, Goggles, Hearing Protection
- ◆ Standard Contractor Tools
 - Hammer, Nail Bag, Tape, Pencil, Level
 - Tin Snips, Chisels, Knife
 - Electric Leads and Power Box
- ◆ Power Saw
 - Preferably Dustless
 - Fitted with a Diamond Blade
- ◆ Vacuum
- ◆ Power drill / Mixing Drill / Mixing Buckets
- ◆ Cordless Drills and Drive Bits
- ◆ Grinder / Reciprocator Saw
- ◆ Adhesive Trowel
- ◆ Hawk and Steel Trowel
- ◆ Nail or Staple Gun
- ◆ Sanding Float / Rasp



Delivery Storage & Handling

Delivery

One AAC Panels are flat-packed delivered to site (20 in a pack for 50mm Panel and 13 in a pack for 75mm Panel) and shall be unloaded or moved with approved lifting devices. For transport and lifting purposes the wet mass of the panels should be used. Each pack has a wet mass of approximately 900kg including the packaging. To minimise double handling and save time the packs should be unloaded as close as possible to the installation area. ONE AAC Panel packs should only be stacked one pack high (on site) and properly supported on level ground. Always consult the project engineer as to the adequacy of the structure to support the packs if they are to be placed on any part of the structure.

Storage

All ONE AAC material should be kept dry and preferably under cover, all care should be taken to avoid damage to the face, ends and edges of the panels. When ONE AAC Panels are stored outside they must be off the ground and protected from the weather.

Manual Handling

Physical manual handling of ONE AAC Panels around the work site should be kept to a minimum, always carry the panels on edge, and support the weight by a two man lift procedure. Where the manual handling becomes excessive with respect to distance from the installation area, ONE AAC recommends the use of trolleys and/or other mechanical devices.

Occupational Health & Safety (OH&S)

ONE AAC Panels, along with all clay, concrete and quarry products contain Crystal line Silica, or Silica Dust. Prolonged exposure to Silica dust without the correct Personal Protection Equipment can be harmful and potentially cause life threatening health hazards such as bronchitis, silicosis and lung cancer.

The ONE AAC Panel itself does not cause health problems, however when cutting, drilling, chasing, sanding, etc., the exposure to high volumes of dust is increased, which increases the potential for health problems to occur, unless standard precautionary measures are taken. Repeatedly breathing in high volumes of dust over many years, may lead to health problems.

It is most unlikely to breath in high volumes of fine silica dust when stacking, loading or laying panels, however when cutting, drilling, chasing, sanding, etc., it is imperative that safety masks, hearing and eye protection is worn. Ensure the mask fits properly and is approved for use with dust. Protective clothing should also be worn e.g. high visibility long sleeve shirt and long pants. These should be washed often and not in the same wash as other clothes.

The site should be cleaned of dust every day, and when using power tools these should be tagged for use as required and be fitted with efficient and well maintained dust extraction devices. The ONE AAC Panel Installer on site has a responsibility to inform all employees of these Health and Safety requirements under the Occupational Health and Safety Act.

Personal Protective Equipment (PPE)

When working with AAC, ONE AAC recommends (as a minimum) that the following PPE is worn:

- ◆ P1 or P2 Dust masks – complying with AS/NZS1715 and AS/NZS1716
- ◆ Glasses / Goggles - complying with AS1336
- ◆ Ear Plugs / Ear Muffs – Class 5
- ◆ Gloves, long sleeve shirt and pants – to prevent possible skin irritation and skin cancer from working outdoors
- ◆ Steel Cap Boots

Cutting

ONE AAC Panels can be easily cut, drilled, or chased using power or hand tools. When working with ONE AAC Panels ensure that the PPE as previously described is worn. As an added measure of containing the dust when working with AAC products, ONE AAC recommends the use of dust extraction equipment.

ONE AAC Panel makes cutting easier for the installer, as they are delivered to site flat packed, essentially each pack of panel is its own cutting bench, simply adjust the depth of the saw blade to the thickness of the panel, and cut the required panels before removing it from the pack. Any exposed reinforcement during cutting must be coated with the ONE AAC Panel Corrosion Protection Touch Up Paint. For a copy of the full range of ONE AAC Panel MSDS sheets, visit the website; www.oneaac.com.au

Hazardous Materials

With reference to the BCA, regarding Hazardous Building Materials, AAC Panels are non-hazardous, provided that all safety precautions included in this literature are adhered to.

Warranty & Guarantee

ONE AAC Panels are quality building products, and come with the following Warranty and Guarantee:

Warranty

ONE AAC Panels and associated materials, when installed as party wall systems, are warranted for a minimum of **15 years** (from the date of purchase), not only meeting, but exceeding the **7 year** requirement outlined in the BCA and the relevant Australian Standards. The ONE AAC Panel products are designed to have a life span significantly in excess of this minimum period.

Guaranteed

ONE AAC Panel Autoclaved Aerated Concrete products are guaranteed to be free of defect in material and manufacture.

For further details or information on the engineering, design and construction with the ONE AAC Panel System, please contact our sales or technical professionals on 1300 010 222 or visit our website: www.oneaac.com.au to obtain the latest Design & Installation Manuals.

SYSTEM 1 – 60 MINUTE OPTION

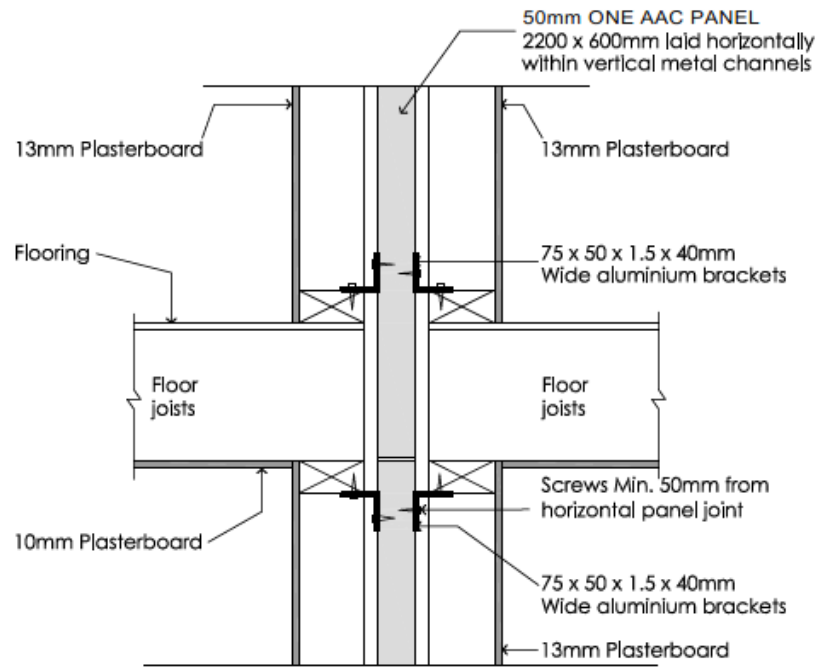
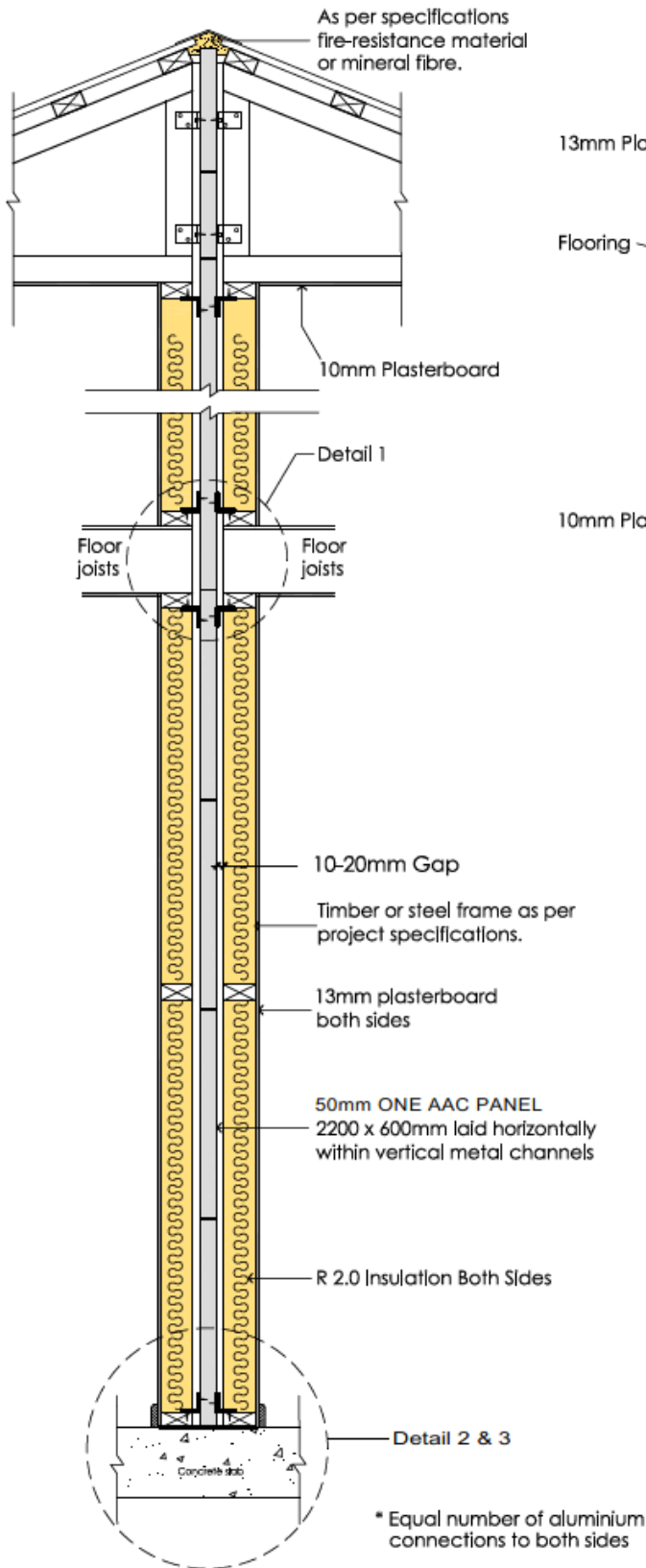

Detail 1

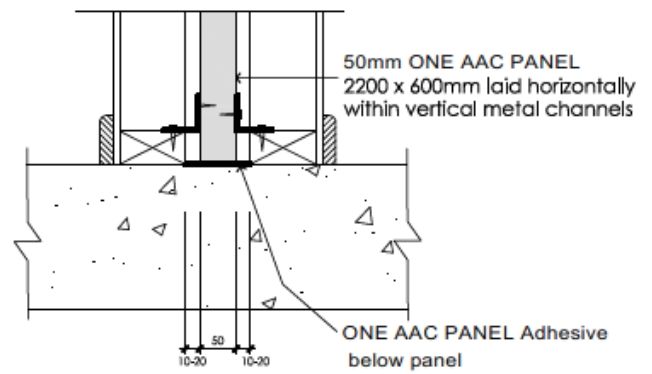

Detail 2 - Option 1

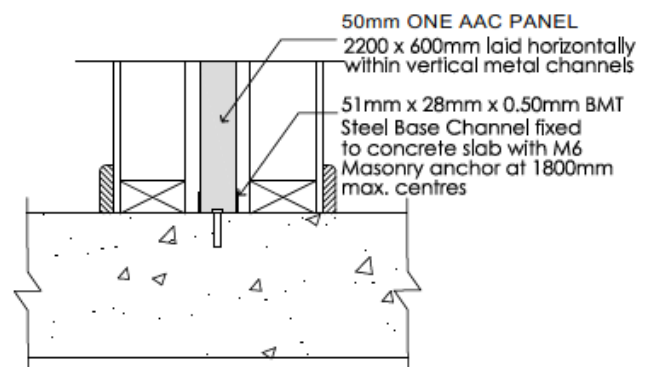

Detail 3 - Option 2

ONE AAC PANEL - PARTY WALL DETAIL - SYSTEM 2
 FRL 60/60/60 Rw+Ctr 53

SYSTEM 1 – 60 MINUTE OPTION

Panel Layout

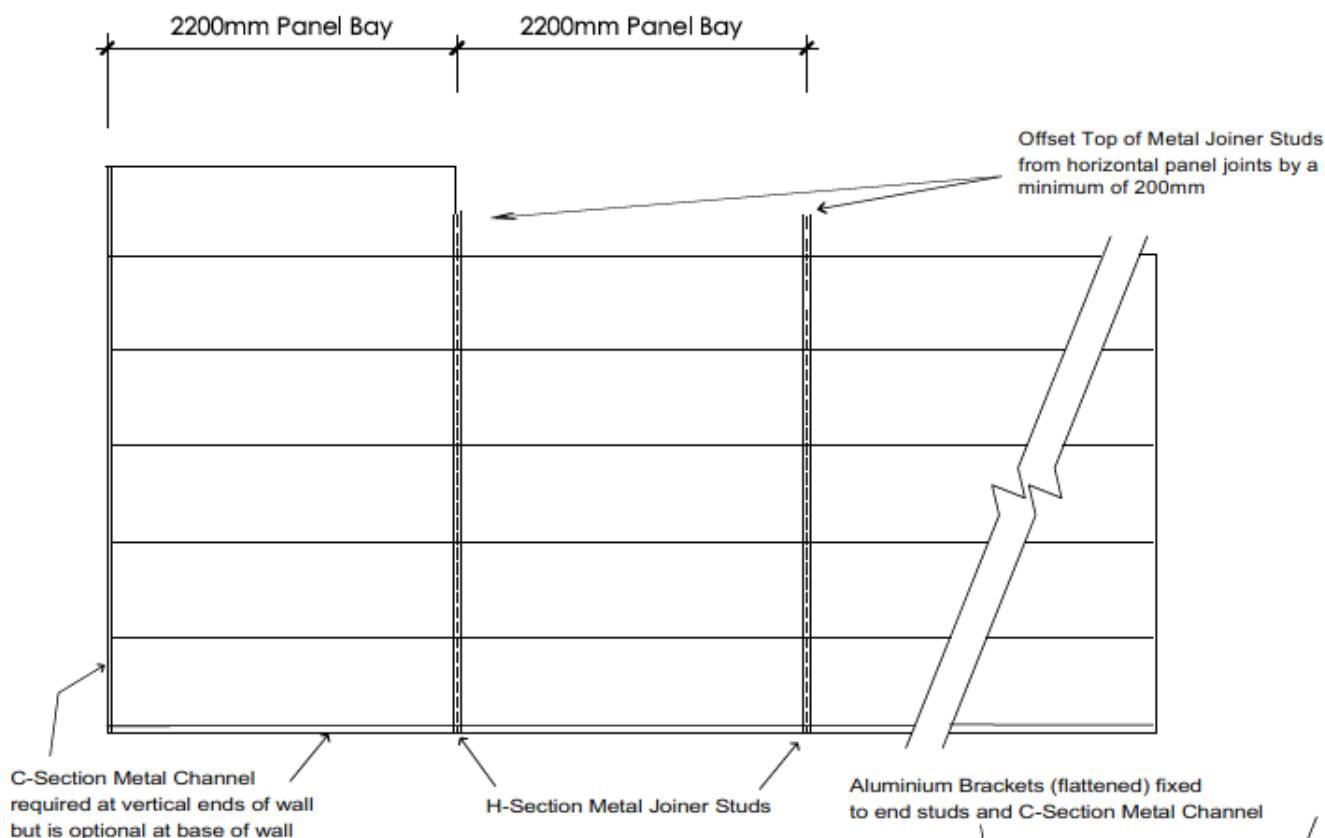

* C-Section Metal Channel required at vertical ends of wall but is optional at base of wall

* H-Section Metal Joiner Studs at vertical panel joints (2200mm maximum spacing)

* Base of Wall - fixed using continuous C-Section Metal Channel or Aluminium brackets fixed to the bottom plate at a maximum of 1100mm centres to both sides of the wall (typically in each H-Section Joiner Stud and at the mid-span of each 2200mm panel)

* All Other Locations - Aluminium brackets fixed to Vertical End Studs of Wall, Top / Bottom Plates, Truss / Roof Space at a maximum of 1100mm centres to both sides of the wall, (typically in each H-Section Joiner Stud and at the mid-span of each 2200mm panel)

* Discontinuous Construction - Only permits Aluminium Brackets fixings to the periphery, i.e.

- Studs at vertical ends of wall
- Bottom and Top Plates at each floor level
- Top of Truss / Roof Space (maximum vertical spacing of 2000mm from previous top plate)

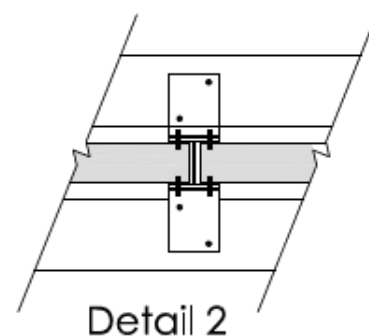
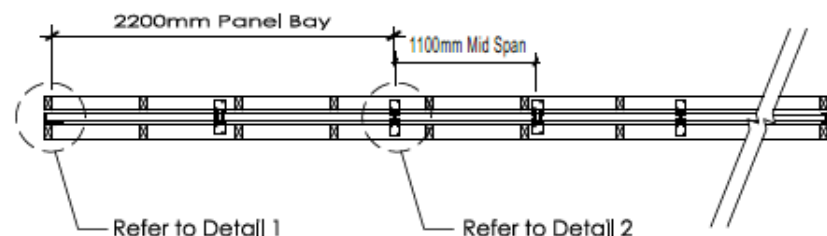
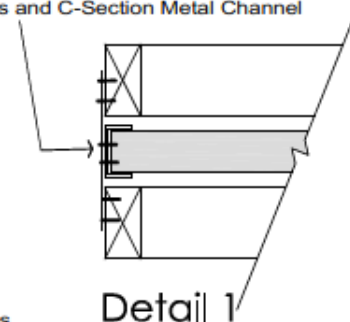

ONE AAC PANEL - PARTY WALL DETAIL - SYSTEM 2
FRL 60/60/60 Rw+Ctr 53

SYSTEM 2 – 90 MINUTE OPTION

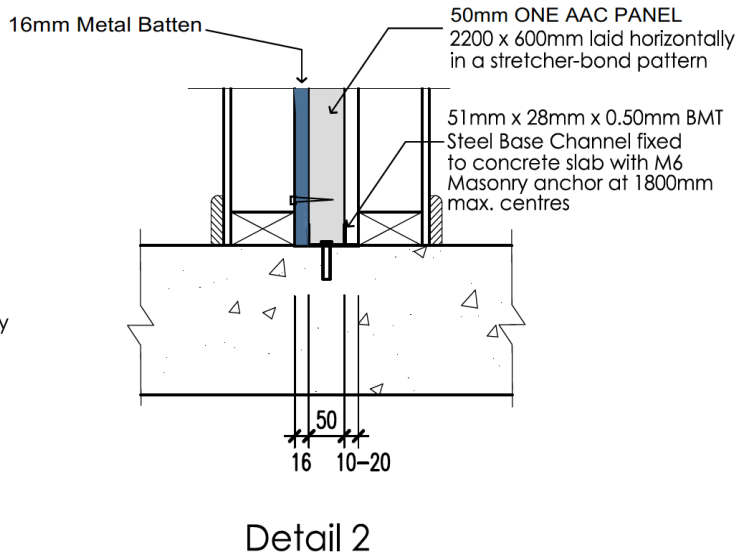
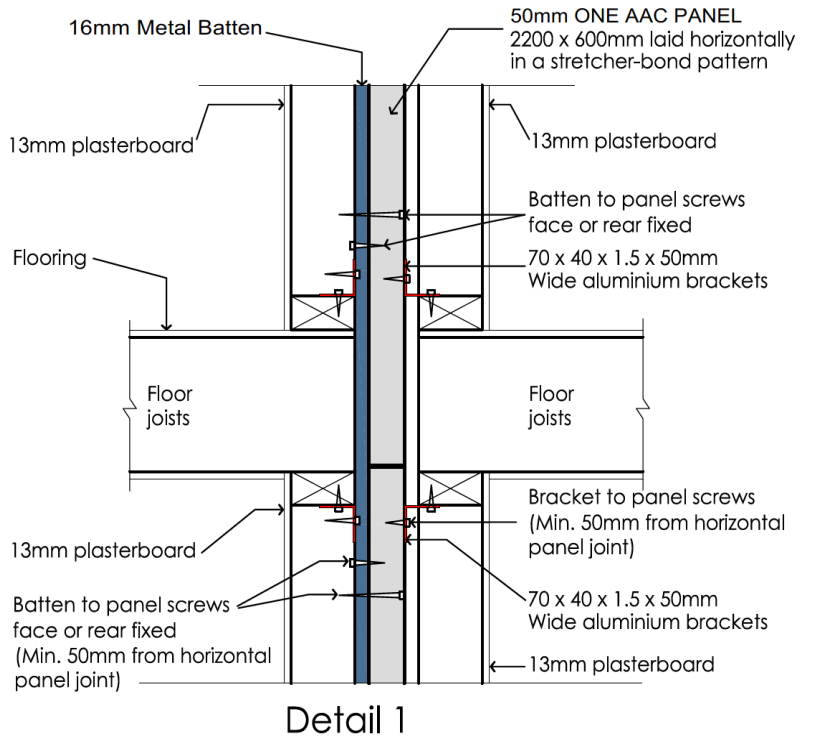
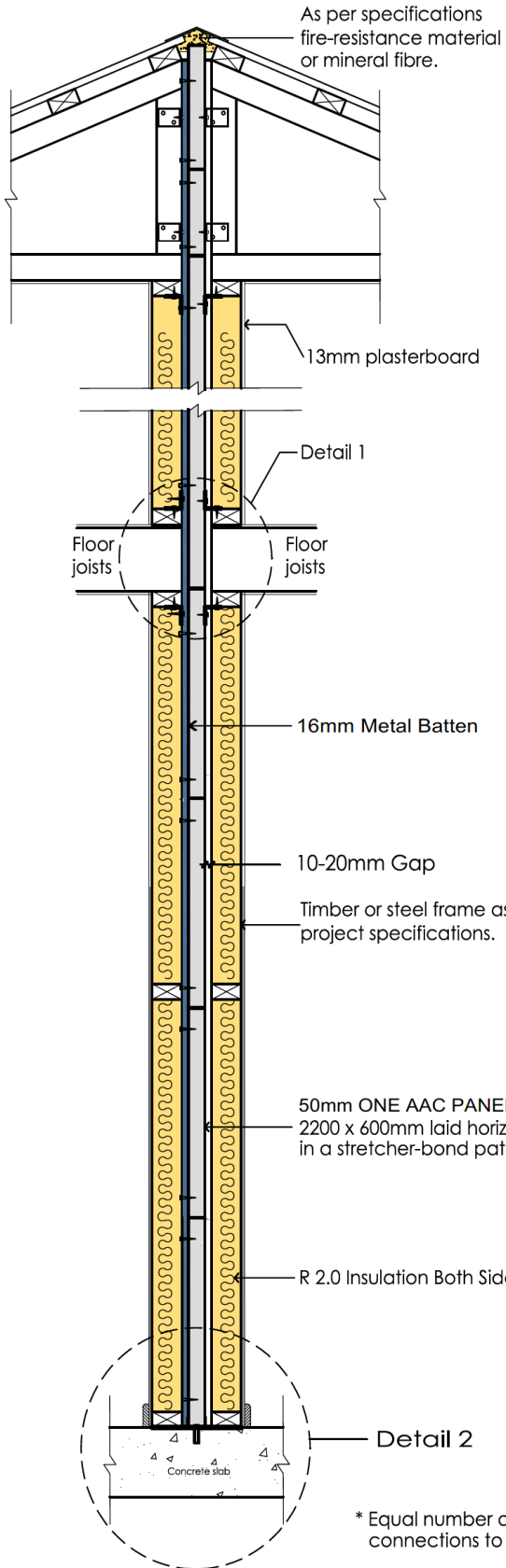

ONE AAC PANEL - PARTY WALL DETAIL - SYSTEM 1 FRL 90/90/90 Rw+Ctr 53

SYSTEM 2 – 90 MINUTE OPTION

16mm METAL BATTEN LAYOUT - ONE SIDE ONLY

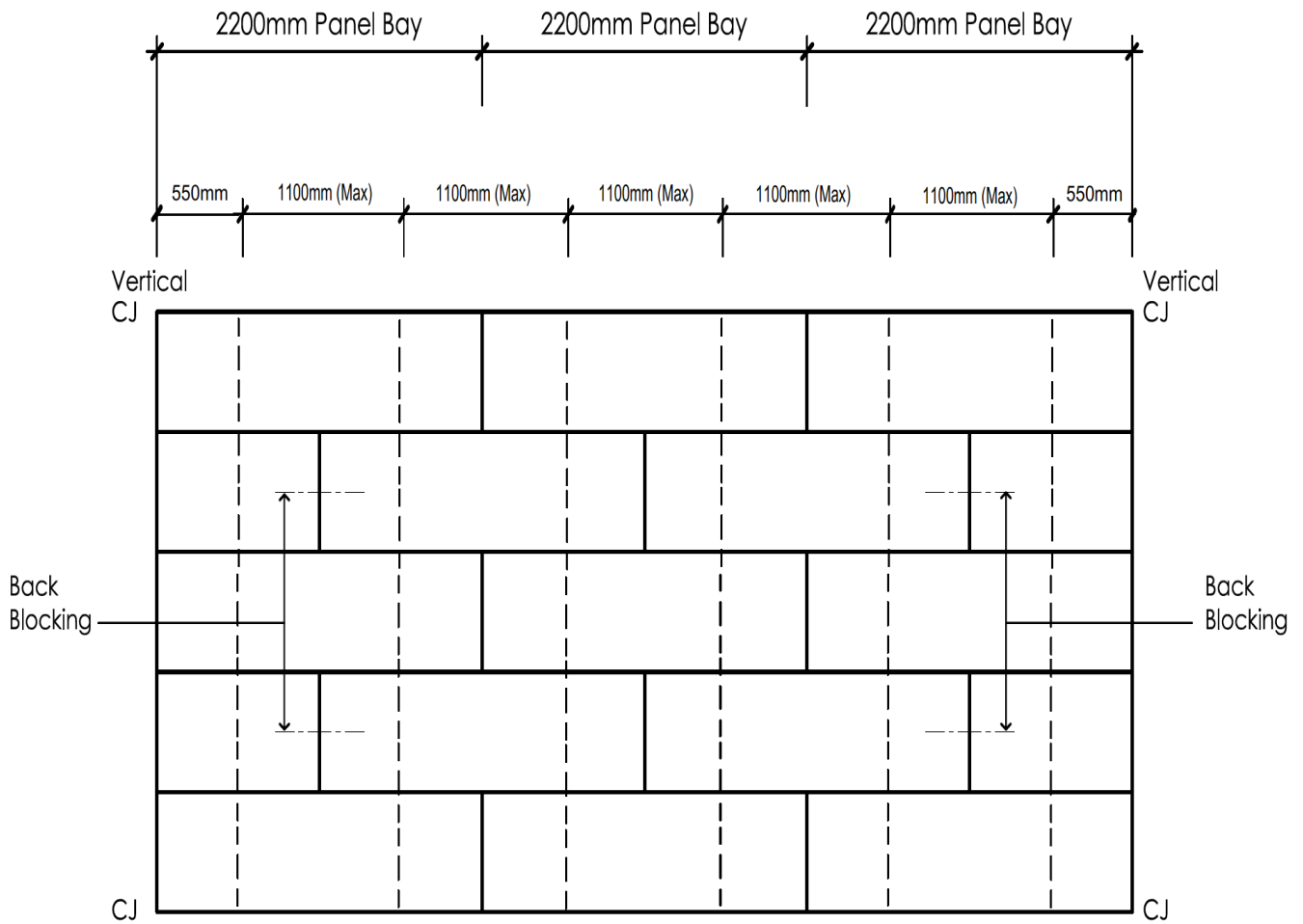

|
 | or — — — Denotes 16mm metal batten
 |

* Vertical control joints at 6.6m

* Horizontal control joints at 8.0m

* Back blocking required if panel is fixed to one batten only.

* 2 Battens required per 2200mm panel bay to a maximum of 1100mm centres.

ONE AAC PANEL - PARTY WALL DETAIL - SYSTEM 1 FRL 90/90/90 Rw+Ctr 53

SYSTEM 3 – 120 MINUTE OPTION

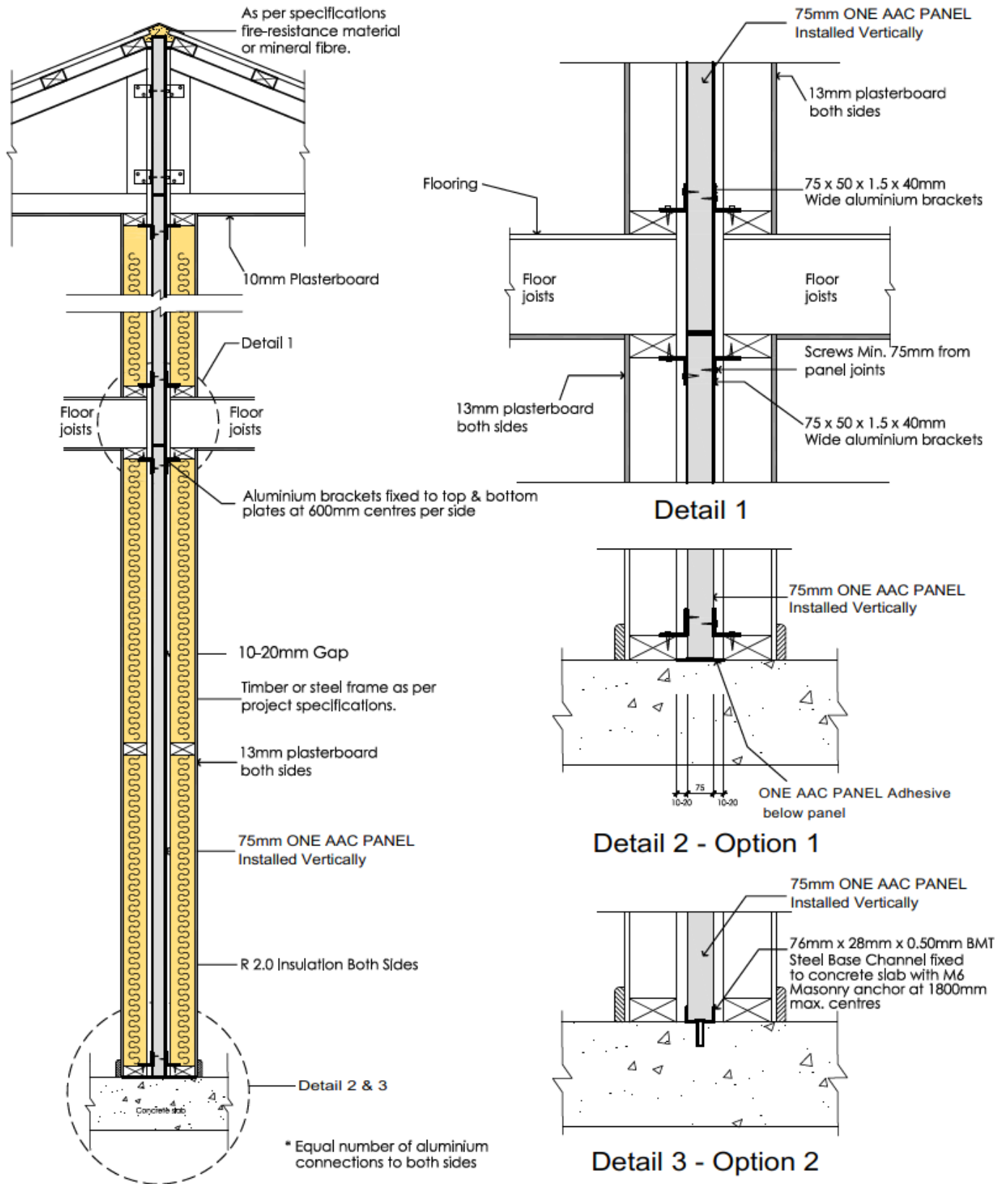

ONE AAC PANEL - 75mm PARTY WALL DETAIL
FRL 120/120/120 Rw+Ctr 55

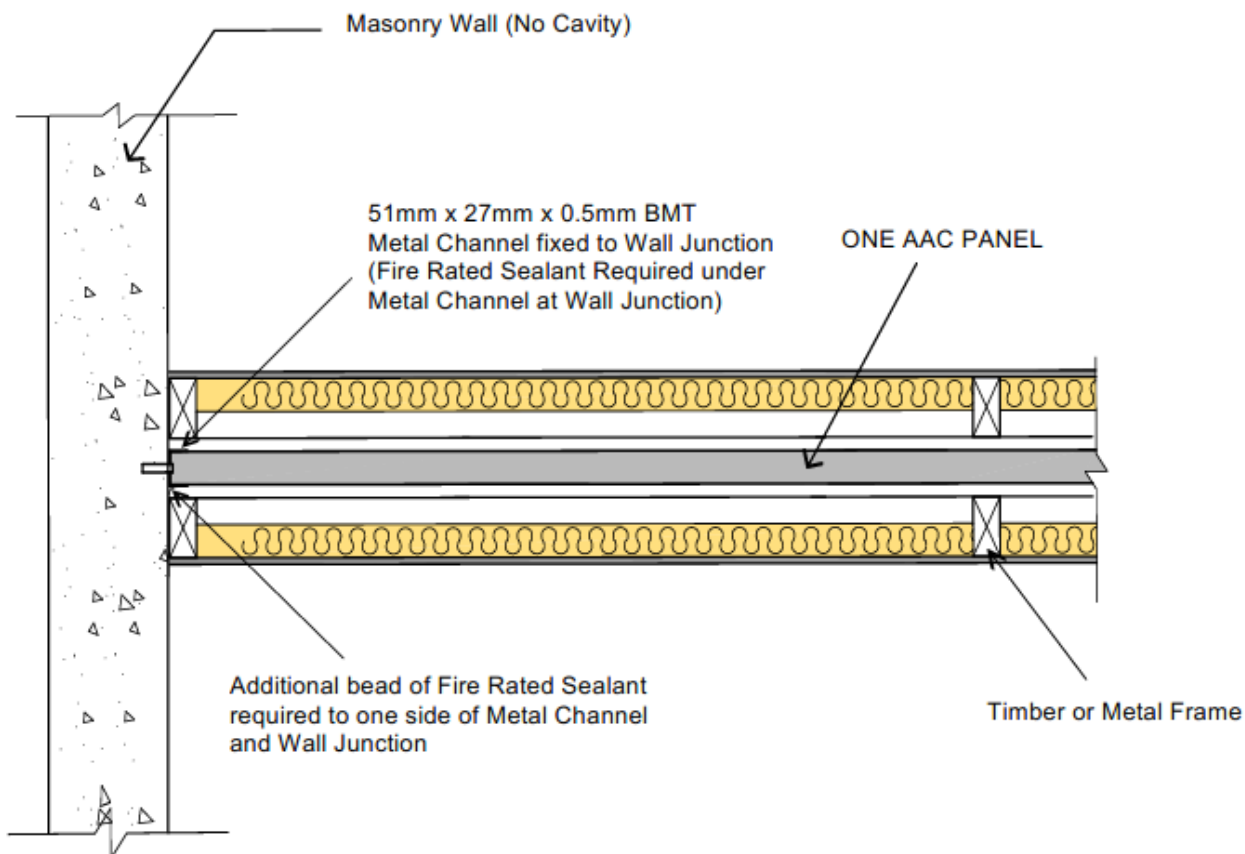

PARTY WALL JUNCTION WITH MASONRY WALL (NO CAVITY OPTION)

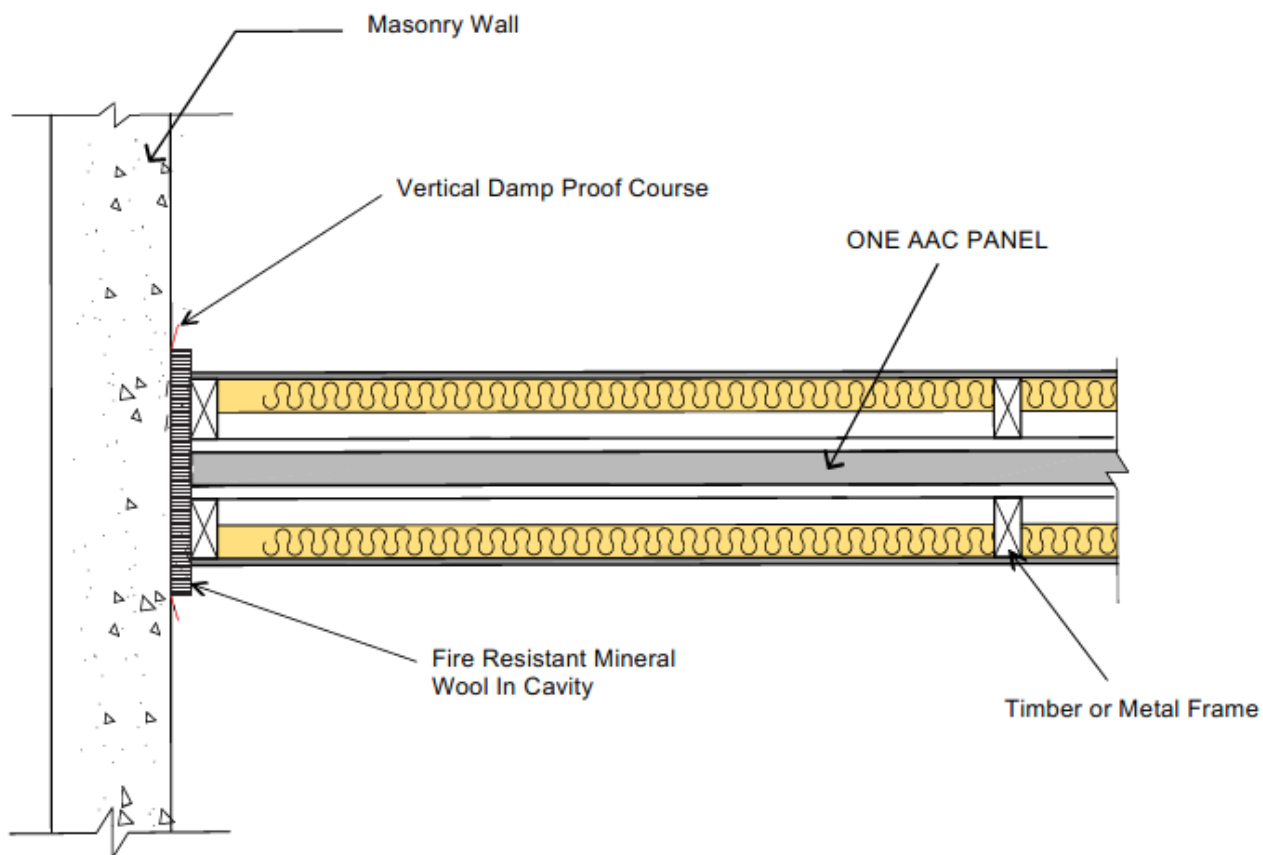

PARTY WALL JUNCTION WITH MASONRY WALL (CAVITY OPTION)



Certificate of Conformity

Certification Body:



Global-Mark Pty Ltd,
Suite 4.07,
32 Delhi Road,
North Ryde NSW
2113, Australia
Ph: +61 2 9886 0222
www.global-mark.com.au

Certificate Holder:

ONE AAC PANEL
485 Campbelltown Rd
Denham Court NSW
2565
Ph: 1300 010 222
www.oneaac.com.au

Certificate number: CM 30031 Rev 1	
THIS TO CERTIFY THAT	
ONE AAC PANEL	
<p>Type and/or use of product: ONE AAC PANELS are reinforced AAC (Autoclaved Aerated Concrete) Panels for use in all building types (BCA Vol 1 & 2), in the following applications:</p> <ol style="list-style-type: none"> 1. Fire, thermal & acoustic rated cladding for load-bearing, single leaf external timber or steel framed walls. 2. Fire, thermal & acoustic rated cladding for load-bearing, dual zero boundary external timber or steel framed walls. 3. Fire barrier with thermal & acoustic rating between timber or steel framing of separate occupancies in residential apartments. 4. Fire, thermal & acoustic rated flooring panels for timber or steel framed floor structures. 	<p>Description of product: Reinforced Autoclaved Aerated Concrete (AAC) Panels in the following sizes:</p> <ul style="list-style-type: none"> • 50mm thickness (2,200mm length x 600mm width), and • 75mm thickness (1,800mm, 2,200mm, 2,400mm, 2,700mm, 2,850mm, 3,000mm & 3,300mm lengths x 600mm width)
COMPLIES WITH THE FOLLOWING BCA PROVISIONS AND STATE OR TERRITORY VARIATION(S)	
BCA 2019	
	Volume One
Performance Requirement(s)	Volume One
	BP1.1
Structural Provisions	Structural Provisions
	BP1.2
Structural Provisions	Structural Provisions
	FP1.4
Damp and Weatherproofing	Damp and Weatherproofing
	Volume Two
	P2.1.1
Structural stability and resistance to actions	Structural stability and resistance to actions
	P2.2.2
Weatherproofing	Weatherproofing

Scope of certification: The CodeMark Scheme is a building product certification scheme. The rules of the Scheme are available at the ABCB website www.abcb.gov.au. This Certificate of Conformity is to confirm that the relevant requirements of the Building Code of Australia (BCA) as claimed against have been met. The responsibility for the product performance and its fitness for the intended use remain with the certificate holder. The certification is not transferrable to a manufacturer not listed on Appendix A of this certificate.

Disclaimer: The Scheme Owner, Scheme Administrator and Scheme Accreditation Body do not make any representations, warranties or guarantees, and accept no legal liability whatsoever arising from or connected to, the accuracy, reliability, currency or completeness of any material contained within this certificate; and the Scheme Owner, Scheme Administrator and Scheme Accreditation Body disclaim to the extent permitted by law, all liability (including negligence) for claims of losses, expenses, damages and costs arising as a result of the use of the product(s) referred to in this certificate. The purpose of Global-Mark construction site audits is to confirm the practicability of installing the product; and to confirm the appropriateness and accuracy of installation instructions. In placing the CodeMark mark on the product/system, the certificate holder makes a declaration of compliance with the certification standard(s) and confirms that the product is identical to the product certified herein. In issuing this Certificate of Approval Global-Mark has relied on the expertise of external bodies (laboratories, and technical experts).

Herve Michoux
Global-Mark Managing Director

Peter Gardner
Unrestricted Building Certifier

Date of issue: 03/10/2019

Date of expiry: 24/09/2022



Certificate number: CM 30031

This certificate is only valid when reproduced in its entirety.

Page 1 of 7

Deemed-to-Satisfy Provision(s):	A5.4	Fire Resistance of Building Elements				
	B1.4 (b) (ii)	Structural Resistance		3.5.4.0	Wall Cladding	
	C1.9	Non-Combustible Material				
	Specification C1.1	Fire-Resisting Construction		3.7.2.4	Fire Safety – Construction of External Walls	
				3.7.3.2	Fire Protection of Separating Walls	
				3.7.3.5	Fire Protection – Horizontal Projections	
				3.7.4.3	Fire Protection of Separating Floors	
	F1.9	Damp-proofing				
	F5.2	Determination of airborne sound insulation ratings		3.8.6.3	Determination of airborne sound insulation ratings	
	F5.3	Determination of impact sound insulation ratings				
	F5.4	Sound Insulation Rating of Floors				
	F5.5	Sound Insulation Rating of Walls		3.8.6.2	Sound Insulation Requirements	
				3.8.6.4	Construction of Sound Insulated Walls	
	G5.2	Construction in bushfire prone areas		3.10.5.0 (c)	Construction in bushfire prone areas	
	J1.5	Building Fabric		3.12.1.4	Building Fabric – External Walls	
State or territory variation(s):	NT Part F5	Sound Transmission & Insulation		NT Part 3.8.6	Sound Insulation	
	NSW G5.2	Construction in Bushfire Prone Areas		NSW 3.10.5.0 (c)	Construction in Bushfire Prone Areas	
				QLD 3.10.5.0 (c)	Construction in Bushfire Prone Areas	
	NSW J(A)1	Building Fabric (Class 2 & 4 only)		NSW 3.12.1	Building Fabric thermal insulation	
	NSW J(B)1	Energy efficiency (Class 3, 5, 6, 7, 8 & 9)				
	NT Section J	Replaced by BCA2009 Section J		NT Part 3.12	Replaced by BCA2009 Part 3.12	
	QLD Section J	Replaced by BCA2009 Section J (Class 2 only)				

SUBJECT TO THE FOLLOWING LIMITATIONS AND CONDITIONS AND THE PRODUCT TECHNICAL DATA IN APPENDIX A AND EVALUATION STATEMENTS IN APPENDIX B

Limitations and conditions:	Building classification/s:
Vol 1 – BP1.1 & Vol 2 – P2.1.1 The wall system as described has maximum design wind load limits documented within the relevant Design & Installation Guides. Wind load limits, construction detail and fixing must follow the relevant details contained within the engineering detail sections of the relevant Design & Installation Manual.	1, 2, 3, 4, 5, 6, 7, 8, 9 & 10
Vol 1 – BP1.1 (b) (vi) and (ix) & Vol 2 – P2.1.1 (b) (v) (vi) and (ix) Snow, liquid pressure and earth pressure actions are excluded.	1, 2, 3, 4, 5, 6, 7, 8, 9 & 10
Vol 1 – BP1.4 & Vol 2 – P2.1.2 Compliance for flood hazard areas is excluded.	1, 2, 3, 4, 5, 6, 7, 8, 9 & 10
Vol1 – C1.9 Non-combustibility relates to AAC material only.	2, 3, 4, 5, 6, 7, 8 & 9
Vol 1 – Spec C1.1 & Vol 2 – 3.7.2.4 Vol 2 – 3.7.3.2 Vol 2 – 3.7.3.5 Vol 2 – 3.7.4.3 Refer to the relevant construction options, details & conditions, included in the relevant ONE AAC Design & Installation Manuals. <ul style="list-style-type: none"> • External wall FRLs of up to 120/120/90 or 120/120/120 are achievable (refer construction options). • Floor FRLs of up to 90/90/90 or 120/120/120 are achievable (refer construction options). • Intertency wall FRLs of 60/60/60, 90/90/90 or 120/120/120 are achievable (refer construction options). • Dual Zero Boundary wall FRLs of 60/60/60 apply. 	1, 2, 3, 4, 5, 6, 7, 8, 9 & 10
Vol 1 – G5.2 & Vol 2 – 3.10.5.0 (c) Construction in Bushfire Prone Areas, up to BAL FZ permitted when constructed in accordance with AS3959.	1, 2, 3 & 10
Vol 1 – J1.5 & Vol 2 – 3.12.1.4 The wall system contributes towards the Total wall system U or R value, which is to be determined in accordance with Vol 1 - J1.5 & Vol 2 - 3.12.1.4. Insulation shall be included within the wall system, as outlined in the relevant Design & Installation Manual & according to project specifications.	1, 2, 3, 4, 5, 6, 7, 8, 9 & 10

Vol 1 – NSW G5.2 & Vol 2 – NSW 3.10.5.0 (c) Construction in Bushfire Prone Areas, up to BAL FZ permitted when constructed in accordance with AS3959.	1, 2, 3 & 10
Vol 1 – QLD G5.1 & Vol 2 – QLD 3.10.5.0 Construction in Bushfire Prone Areas, up to BAL FZ permitted when constructed in accordance with AS3959. This applies to buildings located in a designated Bushfire Prone area but does not apply when the classified vegetation is Group F rainforest (excluding wet sclerophyll forest types), mangrove communities and grasslands under 300mm high.	1, 2, 3 & 10
Vol 1 – NSW J(A)1 & Vol 2 – NSW 3.12.1 Insulation in accordance with NSW BASIX.	1, 2, 4 & 10
Vol 1 – NSW J(B)1 Insulation in accordance with energy efficiency requirements.	3, 5, 6, 7, 8 & 9
Vol 1 – NT & QLD Section J Insulation in accordance with energy efficiency requirements of BCA 2009 Section J.	2, 3, 4, 5, 6, 7, 8 & 9
Vol 2 – NT Part 3.12 Insulation in accordance with building fabric requirements of BCA 2009 Part 3.12.	1 & 10
General Internal linings to be designed & specified in accordance with internal linings manufacturer guidelines or by a suitably qualified building professional.	1, 2, 3, 4, 5, 6, 7, 8, 9 & 10
General The wall system shall be designed & specified by a suitably qualified design professional and installed by suitably qualified and trained building professionals, in accordance with the relevant Design & Installation Manuals.	1, 2, 3, 4, 5, 6, 7, 8, 9 & 10



Certificate of Conformity

APPENDIX A – PRODUCT TECHNICAL DATA

A1 Type and intended use of product

Refer to page 1 of this certificate.

A2 Description of product

Refer to page 1 of this certificate.

A3 Product specification

Refer to items 1, 2, 3, 4 & 5 listed in Appendix B2:

- ONE AAC PANEL External Wall System Design and Installation Manual, dated September 2019.
- ONE AAC PANEL Floor System Design and Installation Manual, dated September 2019.
- ONE AAC PANEL Party Wall System Design and Installation Manual, dated September 2019.
- ONE AAC PANEL Dual Boundary Wall System Design and Installation Manual, dated September 2019.
- ONE AAC PANEL Dual Boundary Wall Presentation (DWG & Photos), dated September 2019.

A4 Manufacturer and manufacturing plant(s)

ONE AAC PANEL

485 Campbelltown Rd

Denham Court NSW 2565

Ph: 1300 010 222

www.oneaac.com.au

A5 Installation requirements

Refer to items 1, 2, 3, 4 & 5 listed in Appendix B2:

- ONE AAC PANEL External Wall System Design and Installation Manual, dated September 2019.
- ONE AAC PANEL Floor System Design and Installation Manual, dated September 2019.
- ONE AAC PANEL Party Wall System Design and Installation Manual, dated September 2019.
- ONE AAC PANEL Dual Boundary Wall System Design and Installation Manual, dated September 2019.
- ONE AAC PANEL Dual Boundary Wall Presentation (DWG & Photos), dated September 2019.

A6 Other relevant technical data

Refer to items 1, 2, 3, 4 & 5 listed in Appendix B2:

- ONE AAC PANEL External Wall System Design and Installation Manual, dated September 2019.
- ONE AAC PANEL Floor System Design and Installation Manual, dated September 2019.
- ONE AAC PANEL Party Wall System Design and Installation Manual, dated September 2019.
- ONE AAC PANEL Dual Boundary Wall System Design and Installation Manual, dated September 2019.
- ONE AAC PANEL Dual Boundary Wall Presentation (DWG & Photos), dated September 2019.

And any referenced documents within the technical literature identified in Appendices A3 & A5.

Certificate number: CM 30031

This certificate is only valid when reproduced in its entirety.

Page 5 of 7

APPENDIX B – EVALUATION STATEMENTS

B1 Evaluation methods

The following assessment methods have been used to determine compliance with NCC 2019:

Code Clause	Assessment Method(s)	Evidence of suitability	Evidence reference in B2
NCC Volume One BP1.1	Combination of A2.2 (2) (a) & (c)	Combination of A5.2 (1) (e) & (f) – Expert judgement & Other documentary evidence	Items 1, 2, 3, 4, 5, 6, 7, 8 & 9
NCC Volume Two P2.1.1	Combination of A2.2 (2) (a) & (c)	Combination of A5.2 (1) (e) & (f) – Expert judgement & Other documentary evidence	Items 1, 2, 3, 4, 5, 6, 7, 8 & 9
NCC Volume One BP1.2	Combination of A2.2 (2) (a) & (c)	Combination of A5.2 (1) (e) & (f) – Expert judgement & Other documentary evidence	Items 1, 2, 3, 4, 5, 6, 7, 8 & 9
NCC Volume One FP1.4	Combination of A2.2 (2) (a) & (c)	A5.2 (1) (e) – Expert judgement	Item 17
NCC Volume Two P2.2.2	Combination of A2.2 (2) (a) & (c)	A5.2 (1) (e) – Expert judgement	Item 17
NCC Volume One A5.4	Combination of A2.3 (2) (a) & (b)	Combination of A5.2 (1) (d) & (e) – Test report & Expert judgement	Items 10, 11, 12, 13, 14, 15 & 16
NCC Volume One B1.4 (b) (ii)	Combination of A2.3 (2) (a) & (b)	Combination of A5.2 (1) (e) & (f) – Expert judgement & Other documentary evidence	Items 1, 2, 3, 4, 5, 6, 7, 8, 9, 17 & 24
NCC Volume Two 3.5.4.0	Combination of A2.3 (2) (a) & (b)	Combination of A5.2 (1) (e) & (f) – Expert judgement & Other documentary evidence	Items 1, 2, 3, 4, 5, 6, 7, 8, 9, 17 & 24
NCC Volume One C1.9	A2.3 (2) (a)	A5.2 (1) (d) – Test report	Item 15
NCC Volume One Spec C1.1	Combination of A2.3 (2) (a) & (b)	Combination of A5.2 (1) (d) & (e) – Test report & Expert judgement	Items 10, 11, 12, 13, 14, 15 & 16
NCC Volume Two 3.7.2.4	Combination of A2.3 (2) (a) & (b)	Combination of A5.2 (1) (d) & (e) – Test report & Expert judgement	Items 10, 11, 12, 13, 14, 15 & 16
NCC Volume Two 3.7.3.2	Combination of A2.3 (2) (a) & (b)	Combination of A5.2 (1) (d) & (e) – Test report & Expert judgement	Items 10, 11, 12, 13, 14, 15 & 16
NCC Volume Two 3.7.3.5	Combination of A2.3 (2) (a) & (b)	Combination of A5.2 (1) (d) & (e) – Test report & Expert judgement	Items 10, 11, 12, 13, 14, 15 & 16
NCC Volume Two 3.7.4.3	Combination of A2.3 (2) (a) & (b)	Combination of A5.2 (1) (d) & (e) – Test report & Expert judgement	Items 10, 11, 12, 13, 14, 15 & 16
NCC Volume One F1.9	Combination of A2.3 (2) (a) & (b)	Combination of A5.2 (1) (e) & (f) – Expert judgement & Other documentary evidence	Items 1 & 19
NCC Volume One F5.2	Combination of A2.3 (2) (a) & (b)	Combination of A5.2 (1) (d) & (e) – Test report & Expert judgement	Items 18, 19, 20 & 21
NCC Volume One F5.3	Combination of A2.3 (2) (a) & (b)	Combination of A5.2 (1) (d) & (e) – Test report & Expert judgement	Items 18, 19, 20 & 21
NCC Volume One F5.4	Combination of A2.3 (2) (a) & (b)	Combination of A5.2 (1) (d) & (e) – Test report & Expert judgement	Items 18, 19, 20 & 21
NCC Volume One F5.5	Combination of A2.3 (2) (a) & (b)	Combination of A5.2 (1) (d) & (e) – Test report & Expert judgement	Items 18, 19, 20 & 21
NCC Volume Two 3.8.6.2	Combination of A2.3 (2) (a) & (b)	Combination of A5.2 (1) (d) & (e) – Test report & Expert judgement	Items 18, 19, 20 & 21
NCC Volume Two 3.8.6.3	Combination of A2.3 (2) (a) & (b)	Combination of A5.2 (1) (d) & (e) – Test report & Expert judgement	Items 18, 19, 20 & 21
NCC Volume Two 3.8.6.4	Combination of A2.3 (2) (a) & (b)	Combination of A5.2 (1) (d) & (e) – Test report & Expert judgement	Items 18, 19, 20 & 21
NCC Volume One G5.2	Combination of A2.3 (2) (a) & (b)	Combination of A5.2 (1) (d) & (e) – Test report & Expert judgement	Items 10, 11, 12, 13, & 16
NCC Volume Two 3.10.5.0 (c)	Combination of A2.3 (2) (a) & (b)	Combination of A5.2 (1) (d) & (e) – Test report & Expert judgement	Items 10, 11, 12, 13, & 16
NCC Volume One J1.5	Combination of A2.3 (2) (a) & (b)	A5.2 (1) (e) – Expert judgement	Items 22 & 23
NCC Volume Two 3.12.1.4	Combination of A2.3 (2) (a) & (b)	A5.2 (1) (e) – Expert judgement	Items 22 & 23



Certificate of Conformity

B2 Reports

The following reports have been used as evidence to determine compliance with NCC 2019:

Ref	Author	Reference	Date	Description	NATA Registration
1	ONE AAC PANEL	External Wall D&I Guide	Sept 2019	Client published design & installation manual	-
2	ONE AAC PANEL	Flooring D&I Guide	Sept 2019	Client published design & installation manual	-
3	ONE AAC PANEL	Party Wall D&I Guide	Sept 2019	Client published design & installation manual	-
4	ONE AAC PANEL	Dual Zero Boundary D&I Guide	Sept 2019	Client published design & installation manual	-
5	ONE AAC PANEL	Dual Zero Boundary Details	July 2019	Client published drawings and details	-
6	Energren	NCC Vol 2 Compliance – Dual Zero	7 Aug 2019	Compliance review of ONE AAC systems against NCC	-
7	Energren	BCA Compliance CodeMark	9 Apr 2013	Compliance review of ONE AAC systems against NCC	-
8	ONE AAC PANEL	LOXO Batch Testing 50mm Panel	15 Mar 2018	Quality control structural test document	-
9	Energren	AS4055-2006 Connection Design	13 Apr 2009	Structural calculation report	-
10	CSIRO	FSV 1525	15 Feb 2012	Fire test report	165
11	CSIRO	COT 2363	15 Feb 2012	Fire test certificate	165
12	CSIRO	FCO 2915	30 Mar 2012	Fire assessment report	165
13	CSIRO	FCO 2944	29 Aug 2012	Fire assessment report	165
14	CSIRO	FCO 3023	20 Sep 2013	Fire assessment report	165
15	CSIRO	FNC-11128	9 May 2014	Fire test report	165
16	CSIRO	FCO 3111	20 Apr 2014	Fire assessment report	165
17	Energren	ONE AAC Weatherproofing	5 Sep 2019	Weatherproofing assessment	-
18	Renzo Tonin & Assoc	TG553-01F02	6 Feb 2014	Acoustic assessment report	-
19	Koikas Acoustics	2679C20150827	3 Jun 2015	Acoustic assessment report	-
20	Koikas Acoustics	2878C20151112	12 Nov 2015	Acoustic assessment report	-
21	Koikas Acoustics	2878C20181031	9 Nov 2016	Acoustic assessment report	-
22	Energren	LOXO Panel R Value	27 Nov 2015	Thermal assessment report	-
23	Energren	LOXO Wall 75mm R Values	9 Apr 2013	Thermal assessment report	-
24	Standards Australia	AS5146 (Parts 1, 2 & 3)	2015	Australian Standard	-

The Certificate Holder has chosen not to make the above identified evidence of compliance publicly available, due to the documents being considered commercial in confidence.

End of Certificate.

Notes:

ONE AAC PANEL

Head Office:

485 Campbelltown Rd

Denham Court NSW 2565

Tel: **1300 010 222 (AAC) or 02 9756 5029**

Mobile: 0439 28 30 30

Email: info@oneaac.com.au

Web: www.oneaac.com.au